

Jan Erik Gulbrandsen • Arve Melhus

nye MEGA 10A

Matematikk for ungdomstrinnet

Fasit

Grunnbok 10A



NYE MEGA 10A

FASIT TIL KAPITTEL A GEOMETRI 1

A 1

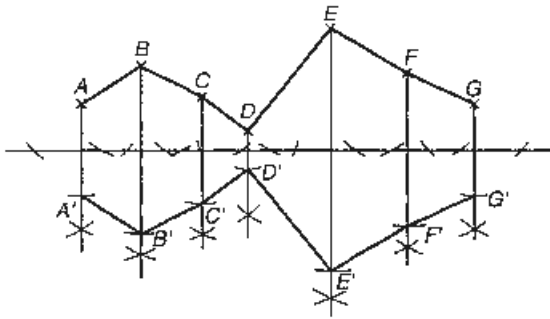

Konstruer speilbildet av endepunktene til linjestykkene og trekk linjer mellom de nye punktene./Konstruer spegelen av endepunkta til linjestykka og dra linjer mellom dei nye punkta.

A 2

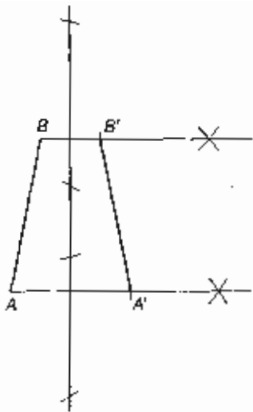

A 3

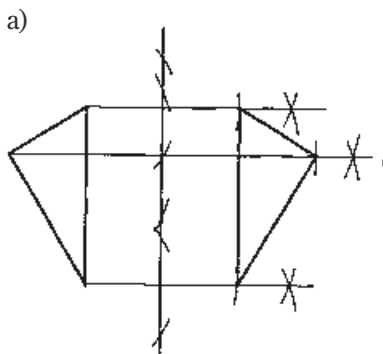

b)

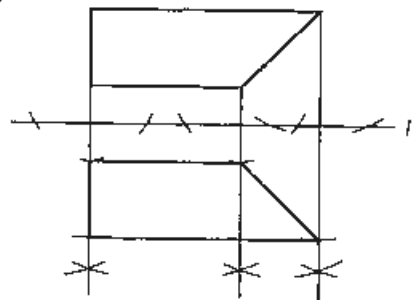

A 7

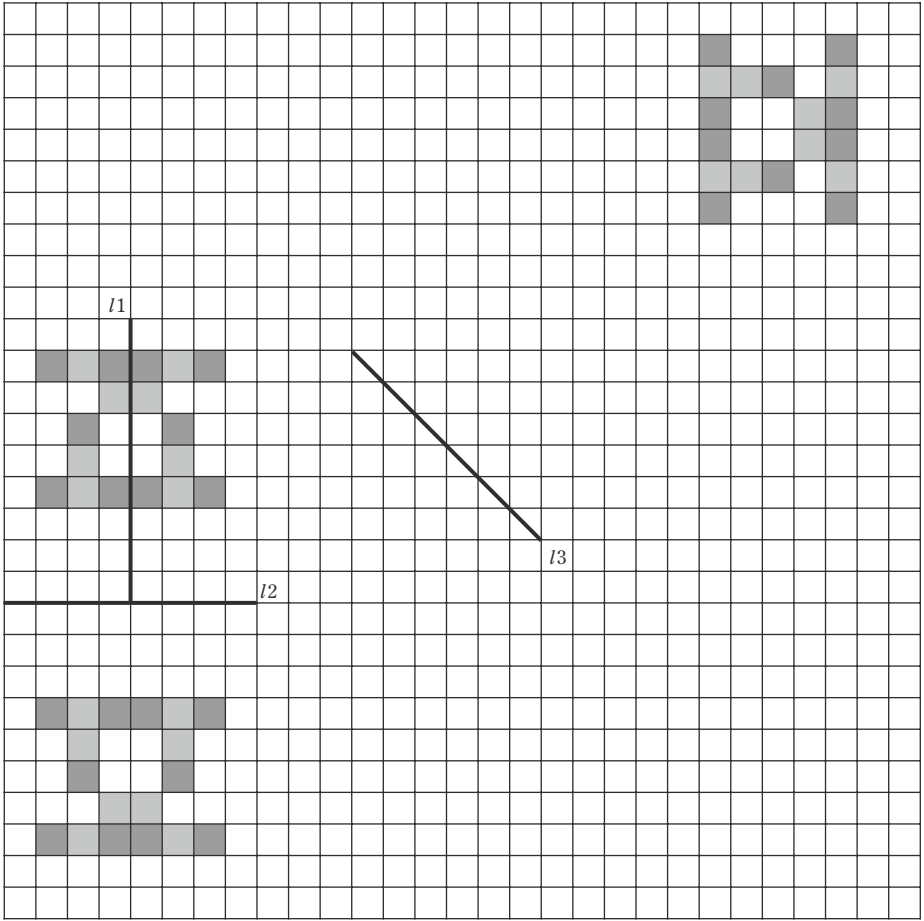

A 8

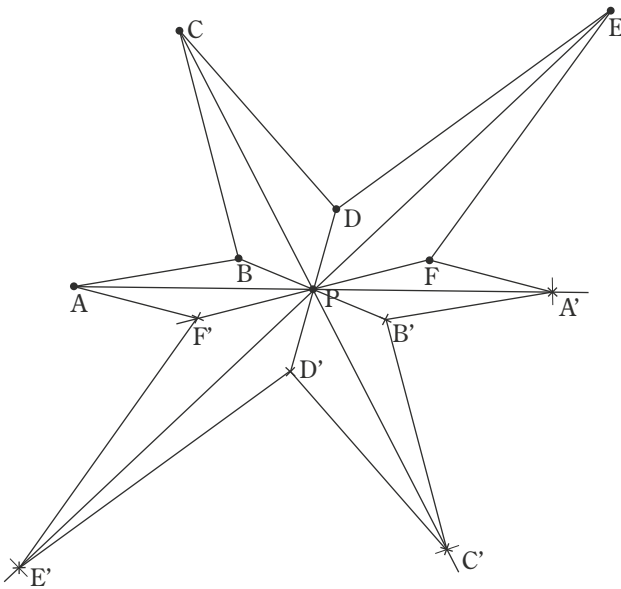

A 9

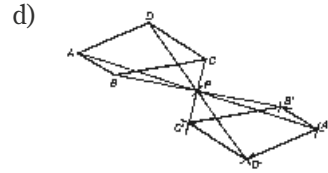
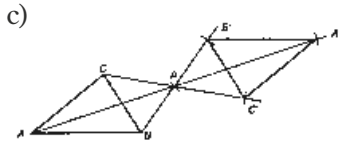
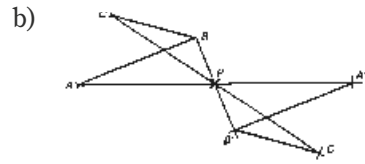
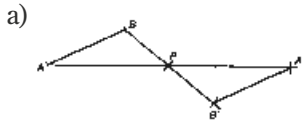

A 10

- a) Rotasjonssymmetrisk om P , 90°
- b) Rotasjonssymmetrisk om P , 60°
- c) Ikke rotasjonssymmetrisk om P /Ikkje rotasjonssymmetrisk om P
- d) Rotasjonssymmetrisk om P , 120°

A 11

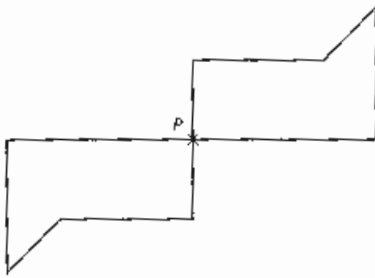

A 12

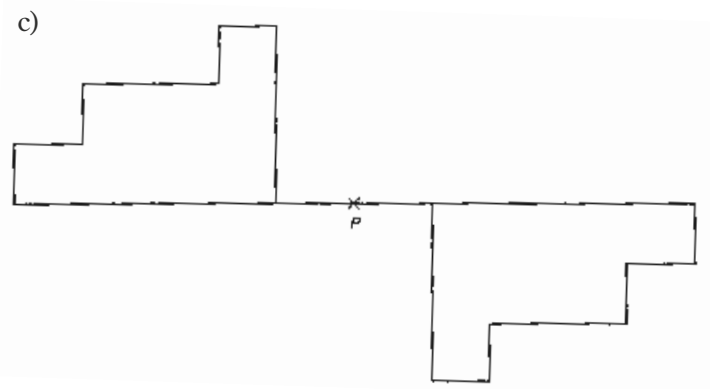
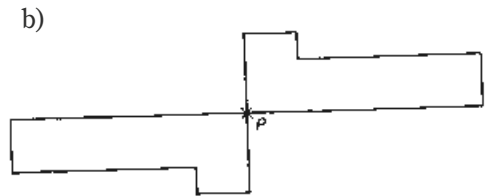
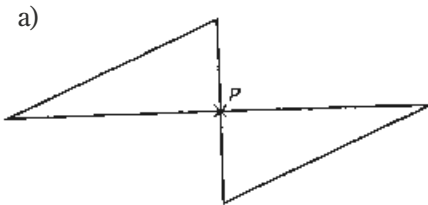

A 13

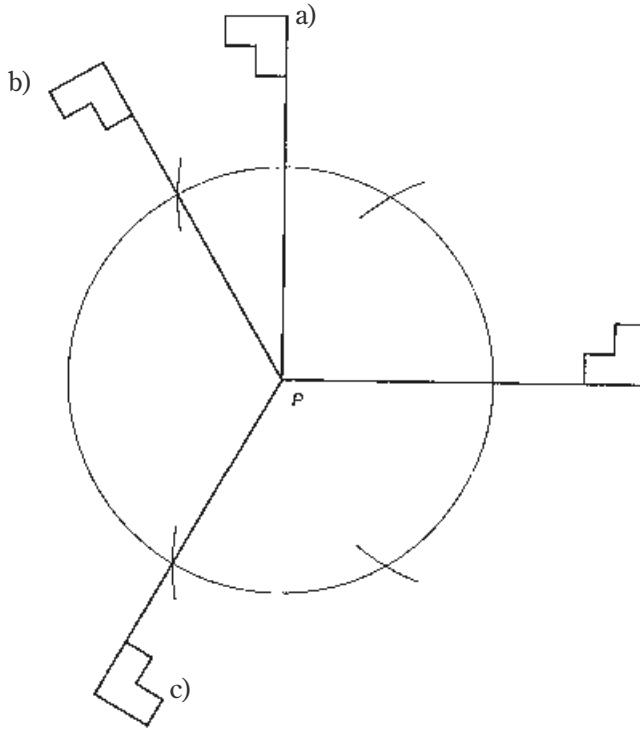

A 14

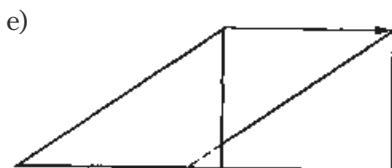
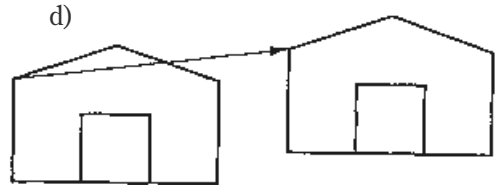
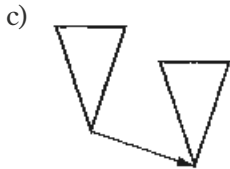
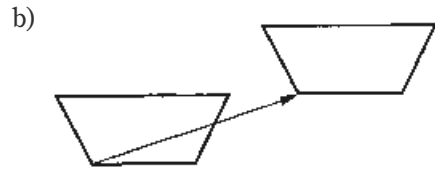
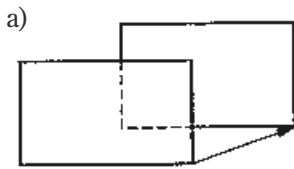

A 15

Par 3 og par 4.

A 16

Fasit viser ikke figurene i riktig størrelse. Målene er riktige./Fasiten viser ikkje figurane i rett storleik. Måla er rette.

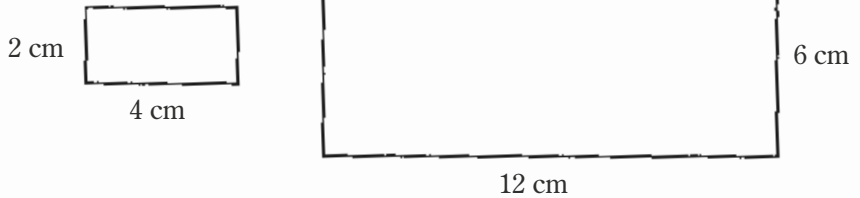
**A 17**

3 : 2

A 18

3 : 2

A 19

a)

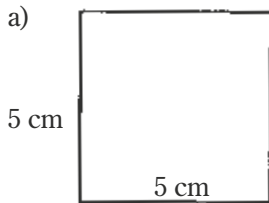

b)

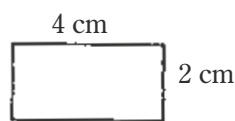

c)

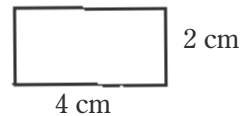

d)

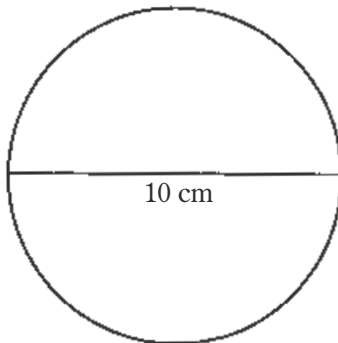
**A 20**

1 : 100

A 21

1 : 5

A 22

1 meter

A 23

b) og c)

A 24

Avbildningen er like stor som originalen./Avbildninga er like stor som originalen.

A 25

a) 1,25 km

b) 2,55 km

c) 3,5 km

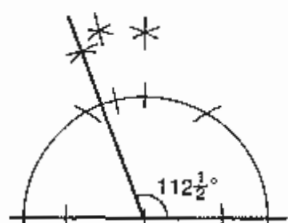
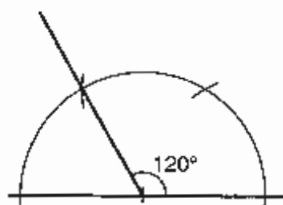
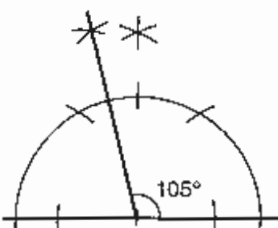
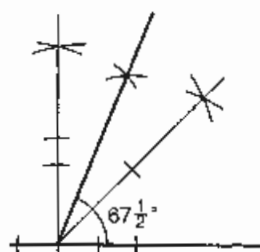
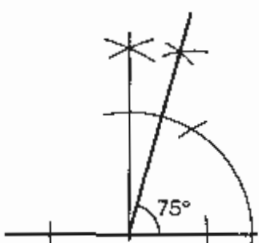
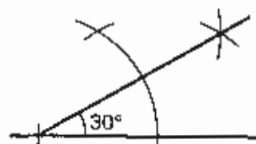
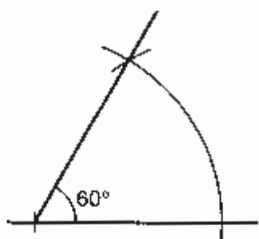
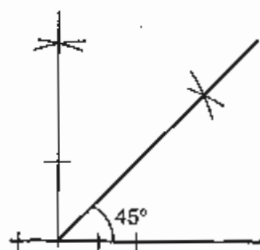
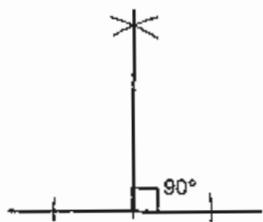

A 27

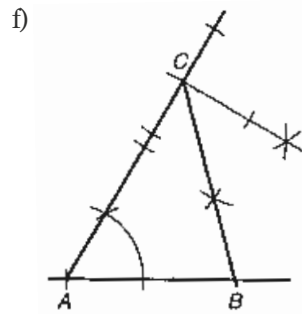
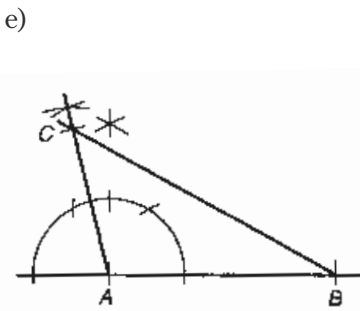
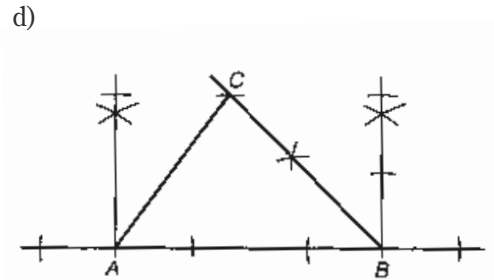
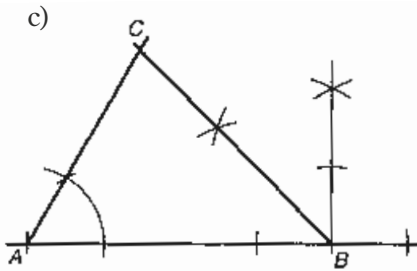
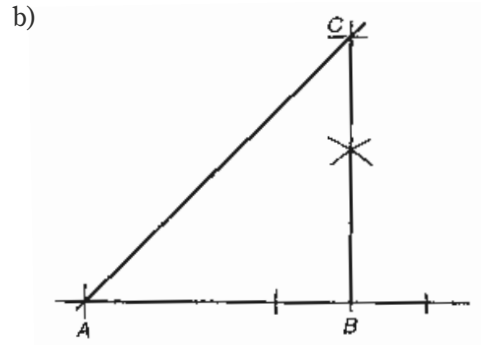
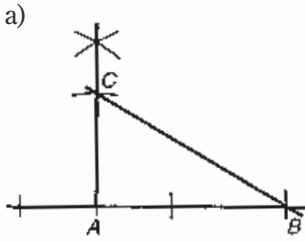

A 28

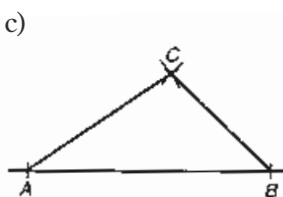
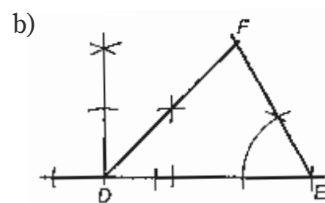
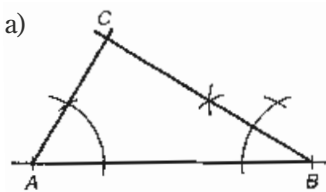

A 29

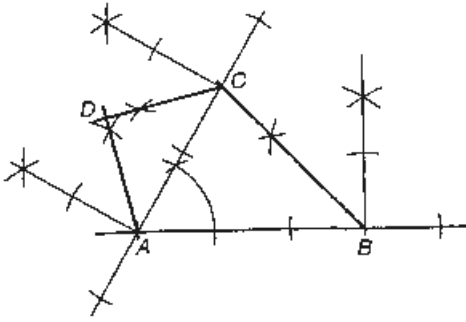

A 30

- a) $\approx 8,6$ cm b) $\approx 5,8$ cm c) $\approx 8,1$ cm

A 31

- a) $\approx 6,7$ cm b) $\approx 6,3$ cm c) $\approx 8,9$ cm

A 32

- a) $\approx 11,4$ cm b) $\approx 10,2$ cm c) $\approx 10,4$ cm

A 33

- a) Nei b) $\approx 4,0$ cm

A 34

Den pytagoreiske læresetning gjelder for rettvinklede trekanter. Denne trekanter er likebeint./Den pytagoreiske læresetninga gjeld for rettvinkla trekantar. Denne trekanten er likebeint.

A 35

- | | | | | |
|------|-------|------|----|----|
| a) 5 | b) Ja | c) a | b | c |
| d) - | e) - | 3 | 4 | 5 |
| | | 5 | 12 | 13 |
| | | 15 | 8 | 17 |

A 36

- | | |
|--------------------------|-------------------------------|
| a) Trekant 1: $x = 8$ cm | b) Trekant 1 $\approx 6,9$ cm |
| Trekant 2: $x = 6$ cm | Trekant 2 $\approx 5,2$ cm |
| Trekant 3: $x = 5$ cm | Trekant 3 $\approx 8,7$ cm |

A 37

- a) og c)

A 38

a)

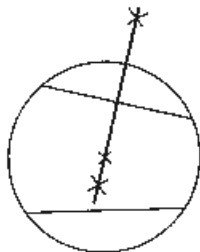

- b) Midtnormalen til korden går gjennom sentrum i sirkelen.

A 39

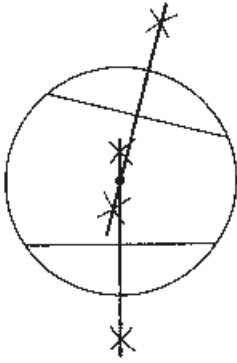

Sentrum i sirkelen ligger på skjæringspunktet mellom de to midtnormalene./Sentrum i sirkelen ligg på skjæringspunktet mellom dei to midtnormalane.

A 40

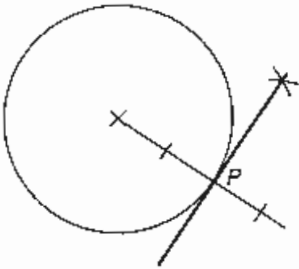

A 41

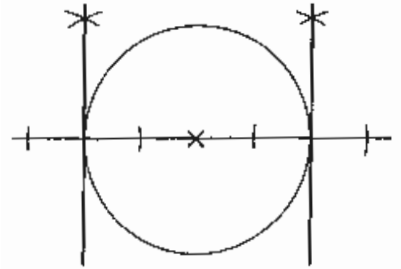

A 42

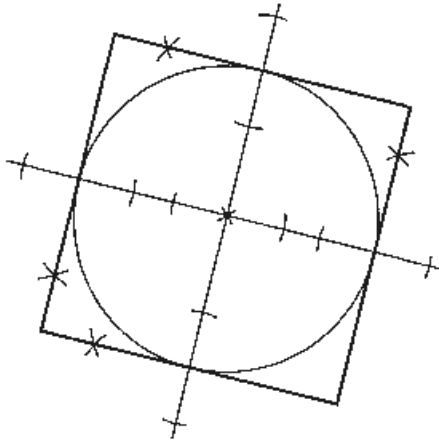

Figuren er et kvadrat med sider lik diameteren, 12 cm./Figuren er eit kvadrat med sider lik diameteren i sirkelen, 12 cm.

A 43

- a) $\approx 55 \text{ cm}^2$ b) $\approx 451,4 \text{ cm}^2$ c) $\approx 25,1 \text{ cm}^2$ d) $\approx 283,5 \text{ cm}^2$

A 44

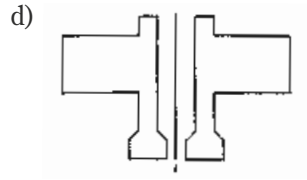
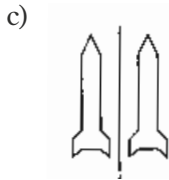
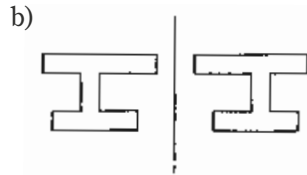
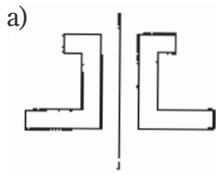

A 45

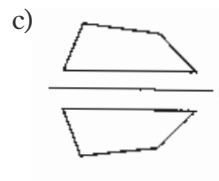
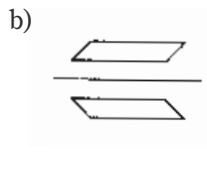
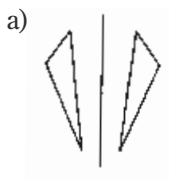

A 46

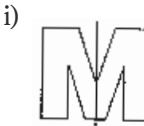
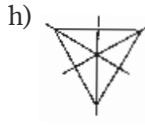
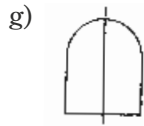
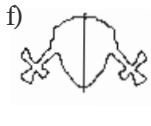
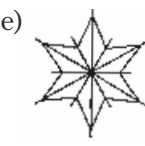
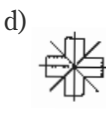
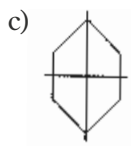
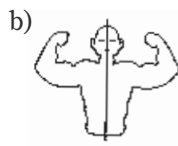
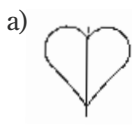

A 47

-

A 48

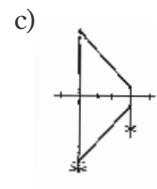
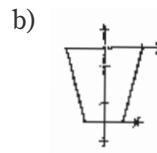
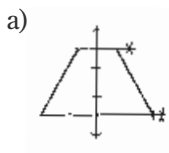

A 49

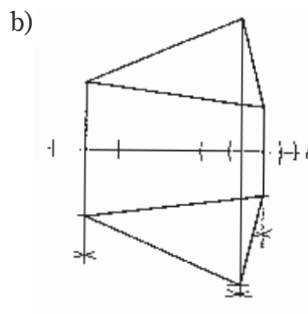
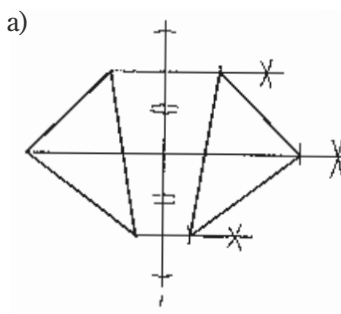

A 50

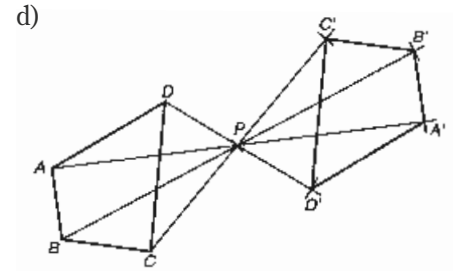
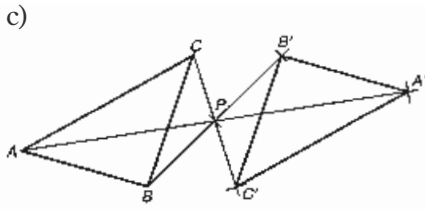
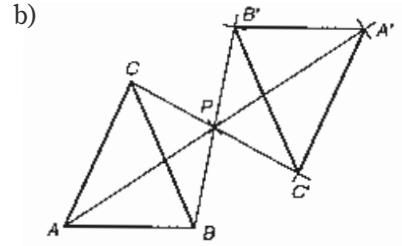
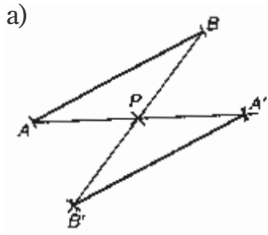

A 51

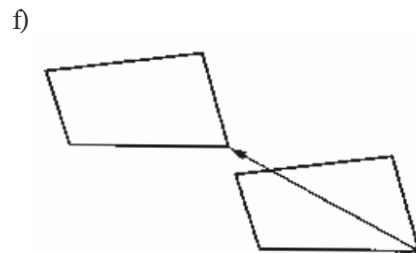
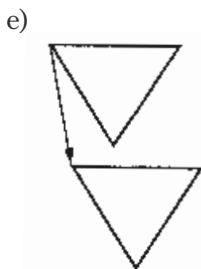
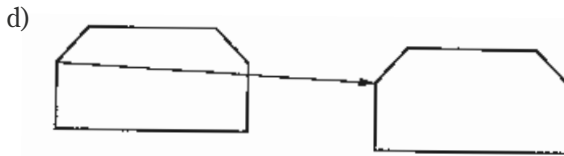
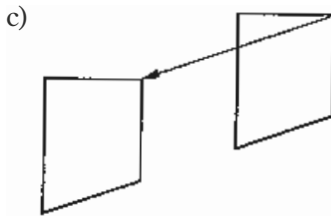
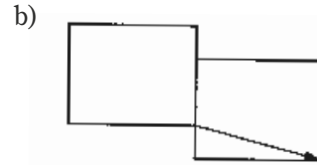
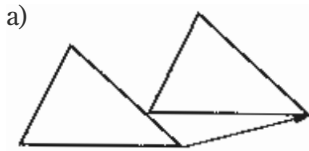

A 52

a)



b)

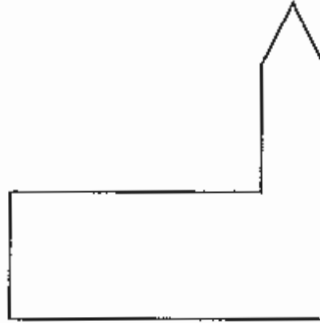

c)

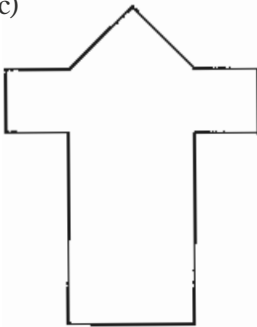

I oppgavene a), b) og c) går vi ut fra ruter på $0,5 \text{ cm} \cdot 0,5 \text{ cm}$.
I oppgavene a), b) og c) går vi ut fra ruter på $0,5 \text{ cm} \cdot 0,5 \text{ cm}$.

A 53

Målestokk 3 betyr at alle figurene skal forstørres tre ganger./Målestokk 3 vil seie at alle figurane skal forstørrast tre gonger.

A 54

- Halver lengdene på figuren.
- Lengdene på den nye figuren blir $\frac{1}{3}$ (formel) av de opprinnelige./Lengdene på den nye figuren blir $\frac{1}{3}$ av dei opphavlege.
- Lengdene på den nye figuren blir $\frac{1}{4}$ av de opprinnelige./Lengdene på den nye figuren blir $\frac{1}{4}$ av dei opphavlege.
- Halver lengdene på figuren.

A 55

a)

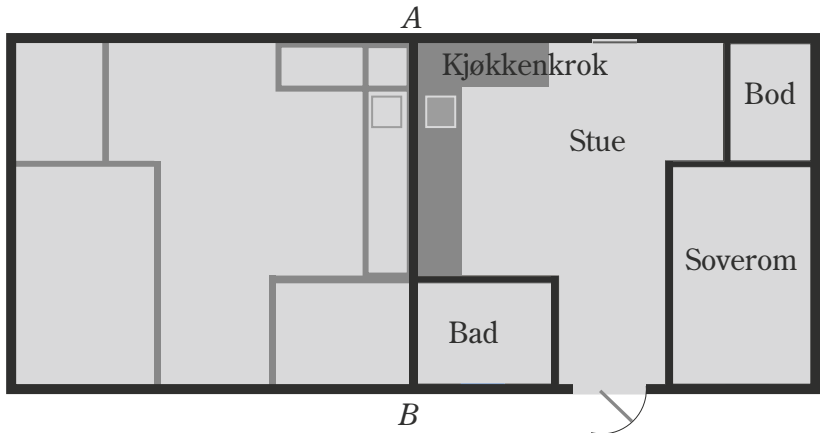

- b) $\approx 23,5 \text{ m}^2$ c) $\approx 5,5 \text{ m}^2$ d) $\approx 2,5 \text{ m}^2$

A 56

-

A 57

- a) 100 m b) Olefjell c) 800 m d) 980 m e) $\approx 2,9 \text{ km}$

A 58

- a) $x \approx 7,2 \text{ cm}$ b) $x \approx 5,7 \text{ cm}$ c) $x \approx 7,6 \text{ cm}$ d) $x \approx 6,4 \text{ cm}$

A 59

- a) $x \approx 4,9 \text{ cm}$ b) $x \approx 7,4 \text{ cm}$ c) $x \approx 6,0 \text{ cm}$ d) $x \approx 3,3 \text{ cm}$

A 60

- a) $x \approx 6,0 \text{ cm}$ b) $x \approx 5,1 \text{ cm}$

A 61

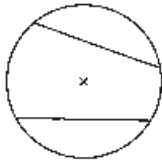

A 62

Diameteren er en korde fordi begge endepunktene ligger på sirkelen./
Diameteren er ein korde fordi begge endepunkta ligg på sirkelen.

A 63

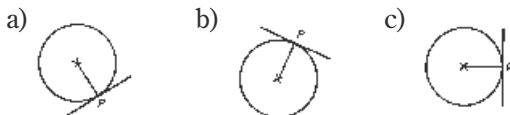

A 64

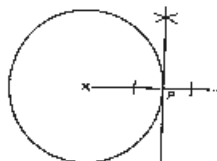

A 65

a) b) c)

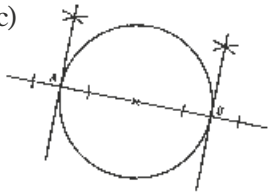

d) Tangentene er parallelle./Tangentane er parallelle.

A 66

a)

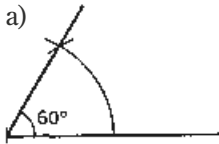

b)

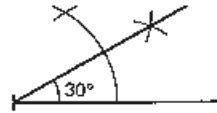

c)

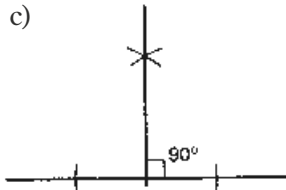

d)

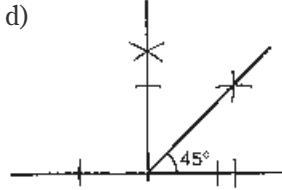

A 67

a)

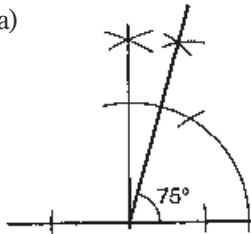

b)

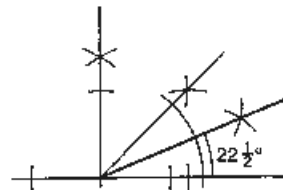

c)

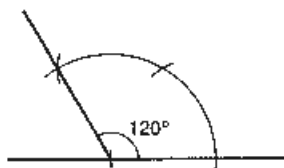

d)

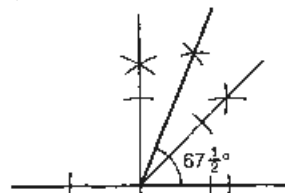

A 68

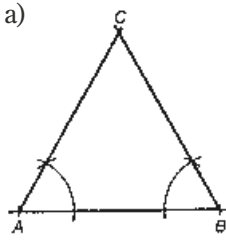

b) $\angle C = 60^\circ$

A 69

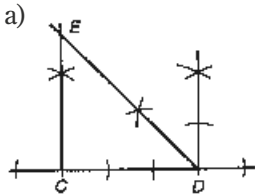

b) $\angle E = 45^\circ$

A 70

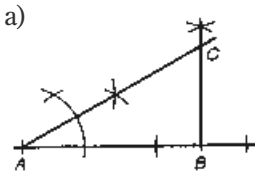

b) $\angle E = 60^\circ$

A 71

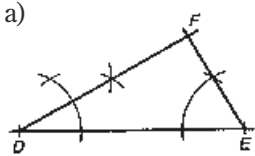

b) $\angle F = 90^\circ$

A 72

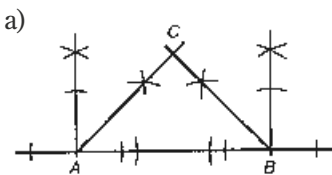

b) $\angle C = 90^\circ$

A 73

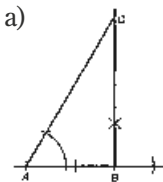

b)

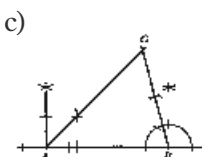
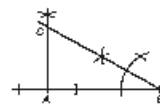

d)

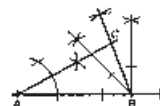

A 74

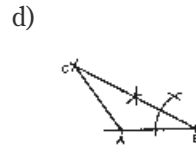
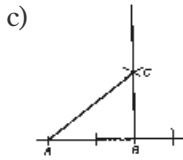
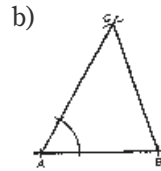
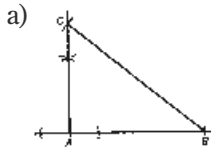

A 75

- a) Rettvinklet trekant/Rettvinkla trekant
- b) Likesidet trekant/Likesida trekant
- c) Likebeint trekant
- d) Rettvinklet, likebeint trekant/Rettvinkla, likebeint trekant
- e) Rettvinklet trekant/Rettvinkla trekant
- f) Likesidet trekant/Likesida trekant

A 76

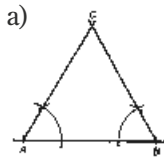

- b) $\angle C = 60^\circ$
- c) Likesidet trekant/Likesida trekant

A 77

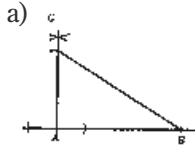

- b) Rettvinklet trekant/Rettvinkla trekant

A 78

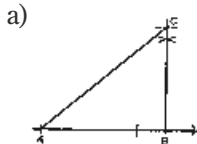

- b) Rettvinklet trekant/Rettvinkla trekant

A 79

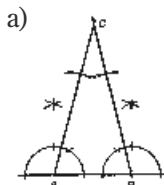

- b) $\angle C = 30^\circ$
- c) Likebeint trekant

A 80

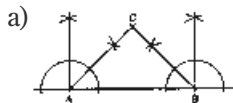

b) $\angle C = 90^\circ$

c) -

A 81

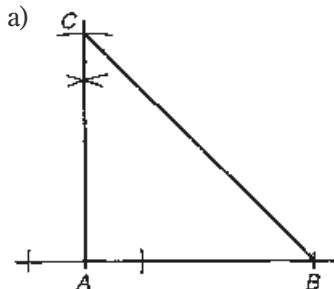

b) $\angle B = \angle C = 45^\circ$

c) Rettvinklet, likebeint trekant/
Rettvinkla, likebeint trekant

d) -

A 82

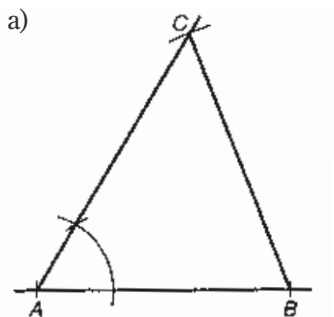

b) -

A 83

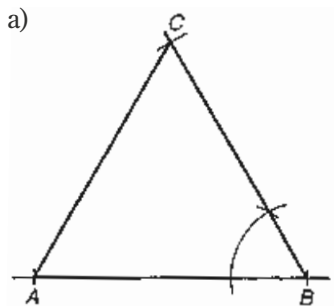

b) $AC = 7,2 \text{ cm}$

c) Likesidet trekant/Likesida trekant

d) -

A 84

100°

A 85

60°

A 86

a) $45^\circ, 45^\circ$ og 90°

b) -

A 87

-

A 88

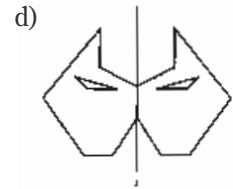
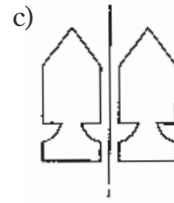
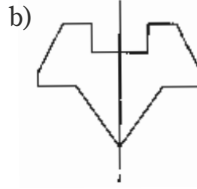
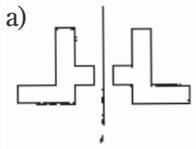

A 89

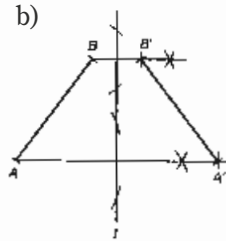
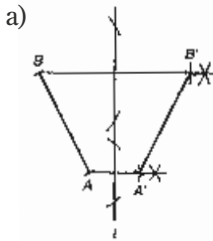

A 90

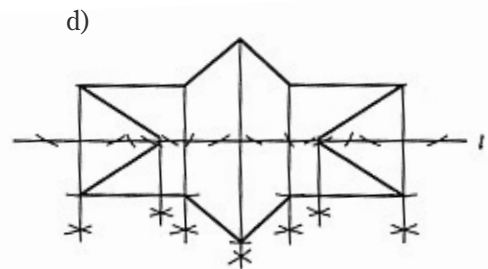
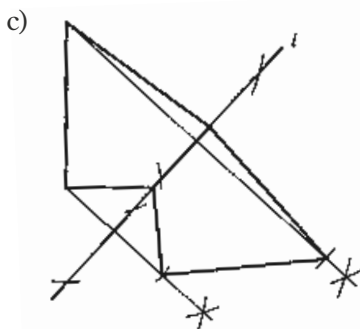
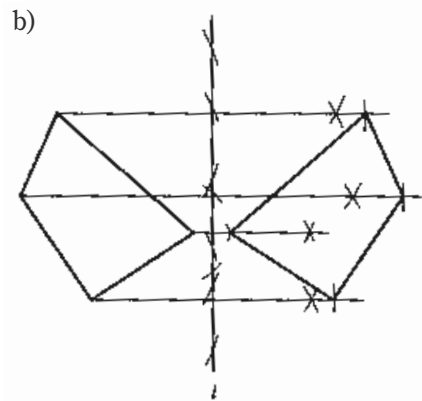
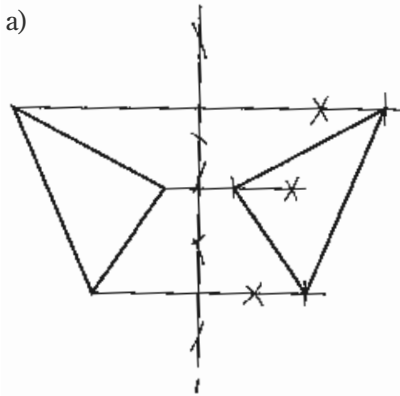

A 91

-

A 92

a) 4

b) 1

c) 8

d) Uendelig mange/Uendeleg mange

e) 4

f) 4

A 93

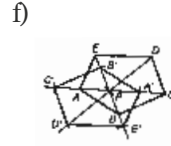
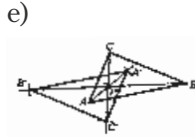
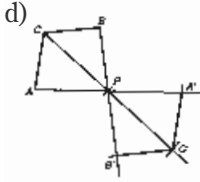
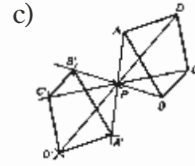
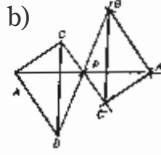
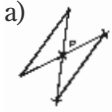

A 94

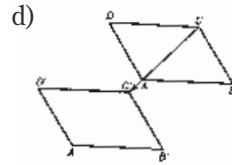
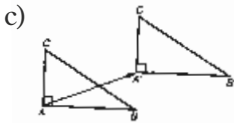
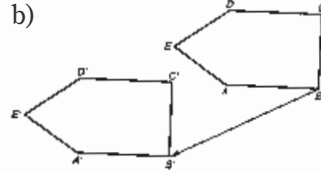
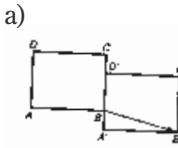

A 95

a) Figuren gjentar seg selv ved dreining.

b) 90°

A 96

a) Linjen dekker hverandre med jevne mellomrom når du dreier om P.

b) 45°

A 97

a)

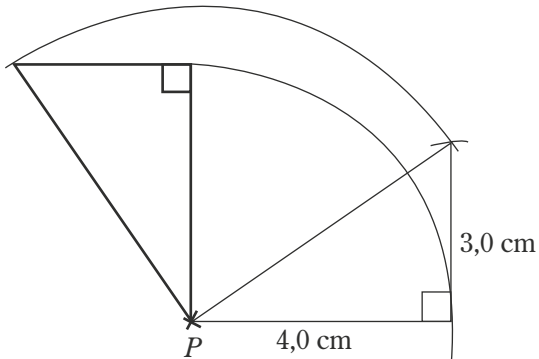

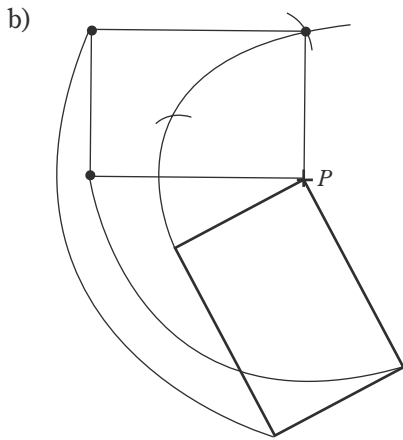

A 98

a) b)

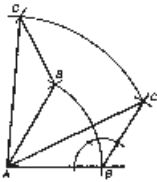

A 99

For eksempel:

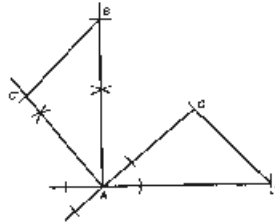

A 100

a) c)

b) Trekanten er likebeint

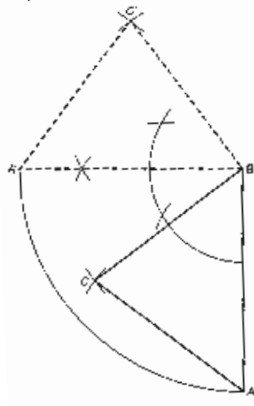

A 101

a)

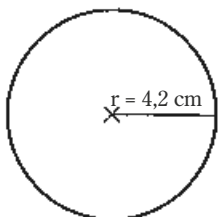

b)

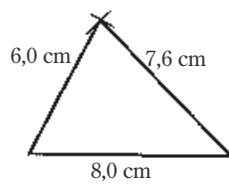

A 102

a)



b)

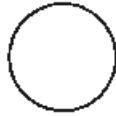

c) og d) Halver længdene på figuren.

A 103

a)

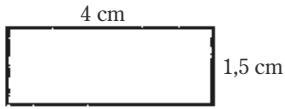

b)

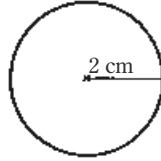

c)

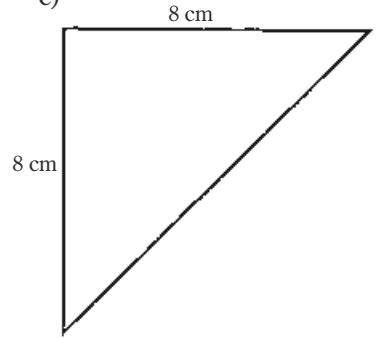

d) Femdobt længdene på figuren.

A 104

a) 24 cm

b) c)

d) $\approx 83 \text{ cm}^2$

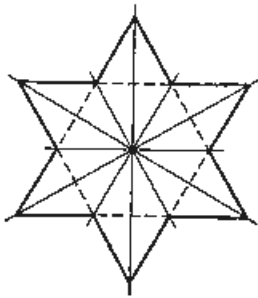

A 105

a) 4,5 cm

b) $28,26 \text{ cm}^2$

c) $63,585 \text{ cm}^2$

d) 2,25 ganger større/2,25 gonger større

A 106

a) 1 km

b) 2,9 km

c) 5,2 km

d) 6,0 km

A 107

a) 1 km^2

b) 3,1 km

c) 1,3 km

d) 3,7 km

A 108

a)

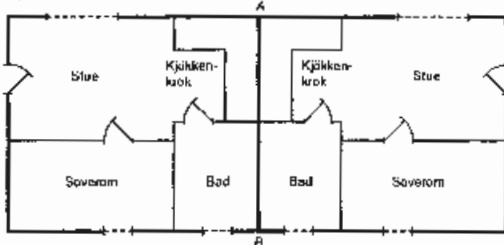

b) $\approx 23,4 \text{ m}^2$

c) $\approx 4,2 \text{ m}^2$

d) $\approx 28 \%$

A 109

-

A 110

120 cm²

A 111

16 m²

A 112

1 : 12

A 113

1 : 50

A 114

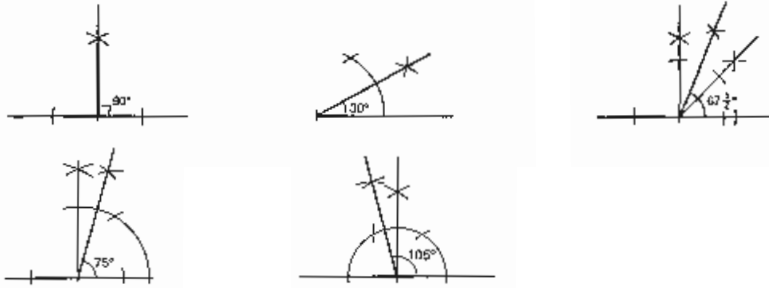

A 115

a)

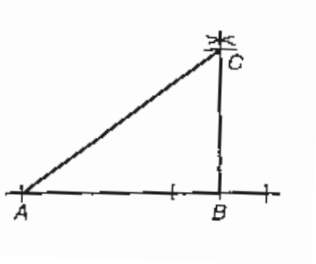

b)

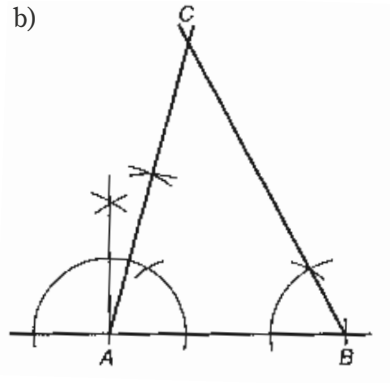

c)

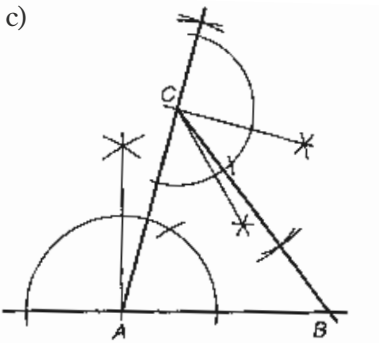

d)

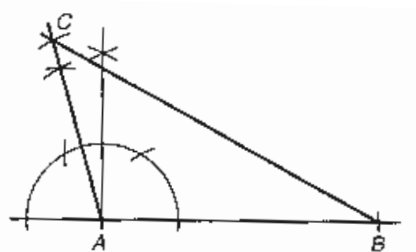

e)

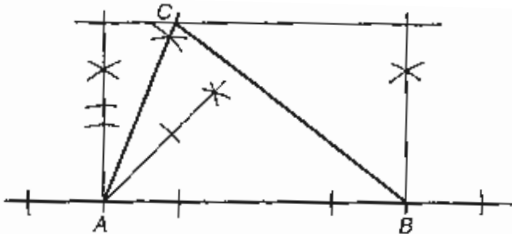

A 116

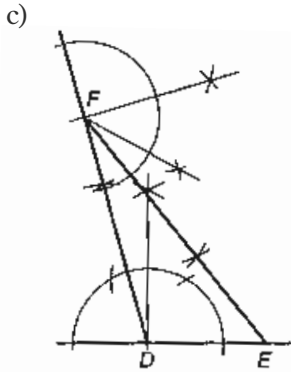
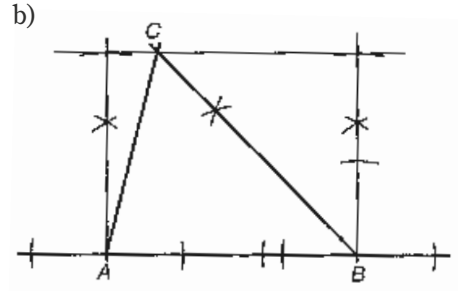
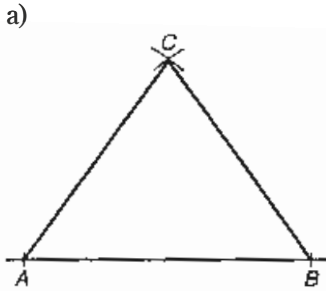

A 117

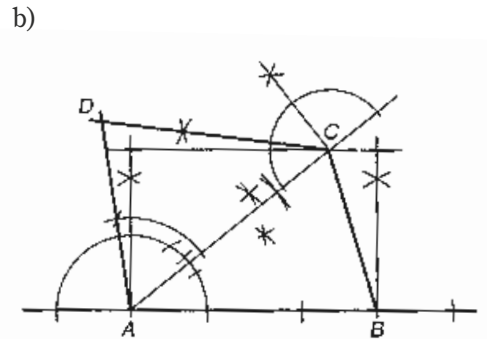
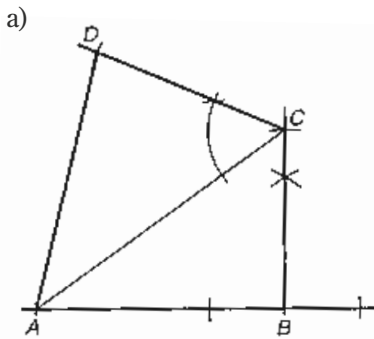

A 118

- a) Rettvinklet trekant/Rett vinkla trekant $\angle C = 90^\circ$
- b) Likesidet trekant/Likesida trekant $\angle C = 60^\circ$
- c) Likebeint trekant $\angle C = 40^\circ$
- d) Likesidet trekant/Likesida trekant $\angle A = \angle B = \angle C = 60^\circ$
- e) Rettvinklet, likebeint trekant/Rettvinkla, likebeint trekant $\angle B = \angle C = 45^\circ$

A 119

- a) $x \approx 7,2$ cm
- b) $x = 7,9$ cm

A 120

- a) $x \approx 6,2$ cm
- b) $x = 6,5$ cm

A 121

- a) $x \approx 9,6$ cm b) $x \approx 7,9$ cm c) $x = 0,6$ cm d) $x \approx 5,7$ cm
e) $x \approx 6,9$ cm f) $x \approx 4,6$ cm

A 122

- a) $x \approx 3,5$ cm b) $x \approx 2,9$ cm

A 123

- a) og d)

A 124

- a)  b) Midtnormalene går gjennom sentrum i sirkelen./
Midtnormalene går gjennom sentrum i sirkelen.

A 125

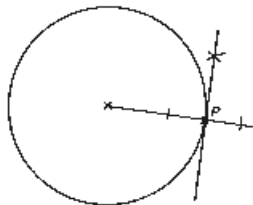

A 126

- a)  b) Tangentene er parallelle./Tangentane er parallelle.

A 127

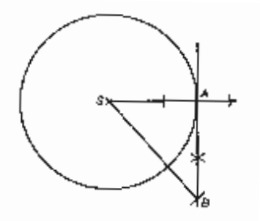

A 128

- a) b)  c) Areal $\approx 7,8$ cm²
Omkrets/Omkrins $\approx 14,2$ cm

A 129

- a) Vinklene er parvis like. b) Lengden på ensliggende sider.

A 130

- a) $\triangle ABC \sim \triangle AEB$ fordi
 $\angle ABC = \angle AEB = 90^\circ$
 $\angle A$ er felles i begge trekantene/er felles i begge trekantane
Siden to av vinklene er parvis like store, er også det tredje paret like stort (vinkelsummen i en trekant er alltid 180°). Konklusjon: Fordi vinklene i trekantene er parvis like store, er trekantene formlike./Sidan to av vinklane er parvis like store, er også det tredje paret like stort (vinkelsummen i ein trekant er alltid 180°). Konklusjon: Fordi vinklane i trekantane er parvis like store, er trekantane formlike.
- b) $\triangle BEC \sim \triangle ABC$ fordi
 $\angle CEB = \angle CBA = 90^\circ$
 $\angle C$ er felles i begge trekantene/er felles i begge trekantane

A 131

- a) $\triangle ABC \sim \triangle AFB$ fordi
 $\angle ABC = \angle AFB = 90^\circ$
 $\angle BAF$ er felles i begge trekantene/er felles i begge trekantane
- b) $\triangle ACD \sim \triangle ADE$ fordi
 $\angle ADC = \angle AED = 90^\circ$
 $\angle DAC$ er felles i begge trekantene/er felles i begge trekantane
- c) 6

A 132

- a) Supplementvinklene til $\angle a$ og $\angle b$ har høyre vinkelbein felles.
De er dermed samsvarende.
- b) l og m må være parallelle.

A 133

- a) –
- b) $\angle a = \angle d$ og $\angle b = \angle c$
 $\angle e = \angle h$ og $\angle f = \angle g$
Toppvinkler
- c) Samsvarende vinkler:
 $\angle b$ og $\angle f$, $\angle d$ og $\angle h$, $\angle c$ og $\angle g$, $\angle a$ og $\angle e$
- d) –
- e) Vi får to like samsvarende vinkler.

A 134

- a) De er toppvinkler./Dei er toppvinklar.
b) De er samsvarende vinkler ved parallelle linjer./Dei er samsvarande vinklar ved parallelle linjer.
c) De er samsvarende vinkler ved parallelle linjer./Dei er samsvarande vinklar ved parallelle linjer.
d) $\triangle CDM \sim \triangle ABM$

A 135

- a) $\triangle ABC \sim \triangle DEC$ fordi
 $\angle BAC = \angle EDC$, samsvarende vinkler ved parallelle linjer er like store/samsvarande vinklar ved parallelle linjer er like store
 $\angle BCA = \angle ECD$, felles i de to trekantene/felles i dei to trekantane
- b) $\triangle BGC \sim \triangle EFC$ fordi
 $\angle BGC = \angle EFC = 90^\circ$
 $\angle BCG = \angle ECF$, felles i de to trekantene/felles i dei to trekantane
- c) $\triangle AGC \sim \triangle DFC$ fordi
 $\angle AGC = \angle DFC = 90^\circ$
 $\angle ACG = \angle DCF$, felles i de to trekantene/felles i dei to trekantane

A 136

- $\triangle ABM \sim \triangle DCM$ fordi
 $\angle AMB = \angle DMC$, toppvinkler og like store/toppvinklar og like store
 $\angle ABM = \angle CDM$, samsvarende vinkler ved parallelle linjer/samsvarande vinklar ved parallelle linjer

A 137

- a) 8,0 cm siden trekantene er formlike b) 2 : 1 c) 1 : 2

A 138

- a) $x = 12,0$ cm b) $x = 3,0$ cm

A 139

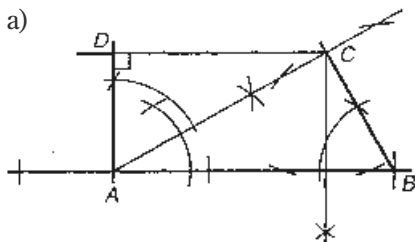

- b) $\triangle ABC$ har vinkler lik/har vinklar lik 30° , 60° og 90° . $BC = \frac{7,4}{2} = 3,7$ cm
- c) $AC \approx 6,4$ cm d) $\angle D = 90^\circ$
- e) $\triangle ABC \sim \triangle CAD$ fordi
 $\angle ADC = \angle ACB = 90^\circ$
 $\angle BAC = \angle DCA$, samsvarende vinkler ved parallelle linjer er like store/
samsvarande vinklar ved parallelle linjer er like store

- f) $AD = \frac{1}{2}AC \rightarrow 3,2 \text{ cm}$ g) Arealet $\approx 20,6 \text{ cm}^2$
 $CD \approx 5,5 \text{ cm}$

A 140

- a) $\triangle ABC \sim \triangle CBD$ fordi
 $\angle ACB = \angle BDC = 90^\circ$
 $\angle B$ er felles i de to trekantene/er felles i dei to trekantane
- b) $AB = 10,0 \text{ cm}$
 $AD = 3,6 \text{ cm}$
 $BD = 6,4 \text{ cm}$
 $CD = 4,8 \text{ cm}$
- c) 24 cm^2
- d) $AC = 6 \text{ km}$, $BC = 8 \text{ km}$, $CD = 4,8 \text{ km}$, $AB = 10 \text{ km}$

A 141

- a) $\angle C = 40^\circ$ b) 12 m c) $DE \approx 4,2 \text{ cm}$
- d) $\triangle DEC \sim \triangle ABC$ fordi
 $\angle ABC = \angle DEC = 90^\circ$
 $\angle BAC = \angle EDC$, samsvarende vinkler ved parallelle linjer/samsvarande vinklar ved parallelle linjer
- e) $BC = 7,1 \text{ cm}$ f) $85,2 \text{ m}^2$

A 142

- a) $\approx 37,7 \text{ cm}^2$ b) $\approx 83,7 \text{ cm}^2$ c) $\approx 7,9 \text{ cm}^2$ d) $\approx 47,3 \text{ cm}^2$

A 143

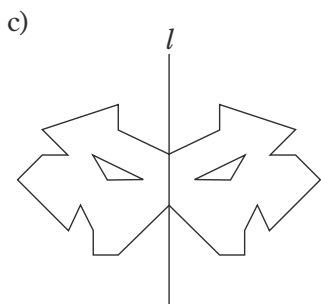
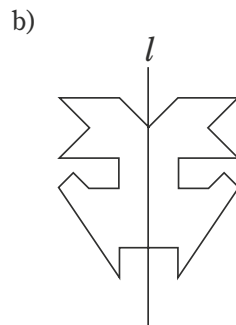
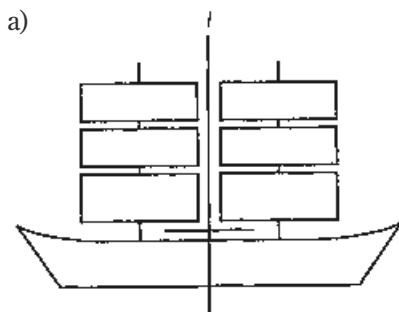

A 144

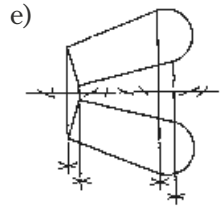
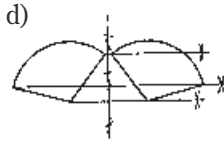
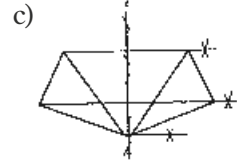
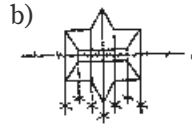
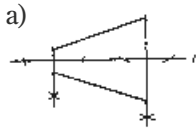

A 145

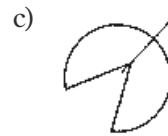
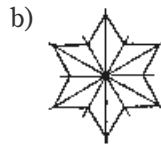
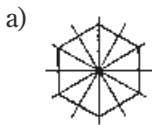

A 146

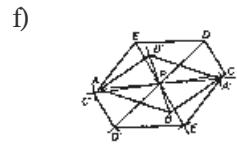
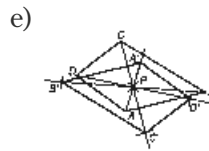
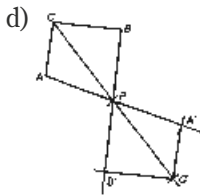
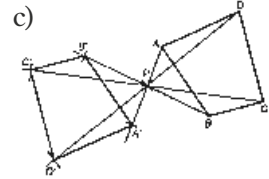
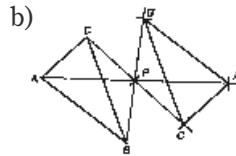
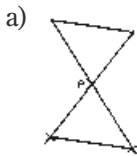

A 147

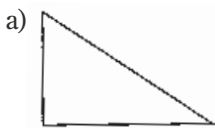

målene 3 ganger så store

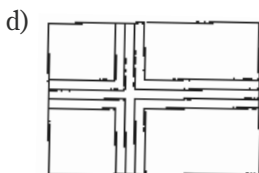
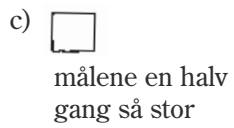

målene 5 ganger så store

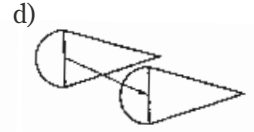
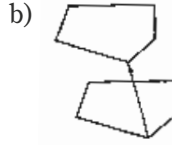
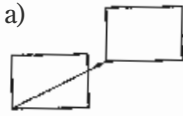
A 148**A 149**

$1,2 \text{ m} \cdot 1,8 \text{ m}$

A 150

$1 : 8$

A 151

a) 300 cm^2

b) 9 ganger mindre

A 152

-

A 153

a) $39,25 \text{ cm}^2$

b) 157 m^2

c) 16 %

d) 19 m^2

e) 12 %

A 154

a) 1 km^2

b) $\approx 1,8 \text{ km}$

c) $\approx 2,5 \text{ km}$

d) $\approx 3,3 \text{ km}$

A 155

a) $\approx 6,7 \text{ km}$

b) $\approx 2,7 \text{ km}$

c) 60 m

d) $\approx 17,8 \text{ km}$

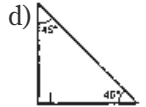
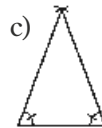
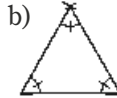
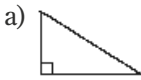
A 156**A 157**

Nei. Alle vinklene er like store, og når vinkelsummen i en trekant er 180° , blir alle vinklene 60° ./Nei. Alle vinklene er like store, og når vinkelsummen i en trekant er 180° , blir alle vinklene 60° .

A 158

a) $x \approx 4,4 \text{ cm}$

b) $x \approx 2,2 \text{ cm}$

c) $x \approx 3,2 \text{ cm}$

d) katet $\approx 3,5 \text{ cm}$
hypotenus $\approx 7,0 \text{ cm}$

e) $s \approx 4,2 \text{ cm}$

f) Begge katetene $\approx 3,7 \text{ cm}$

A 159

a) b)

c) Areal $\approx 42,3 \text{ cm}^2$

Omkrets/Omkrins: 26 cm

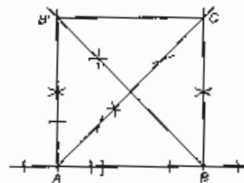
**A 160**

a) d)

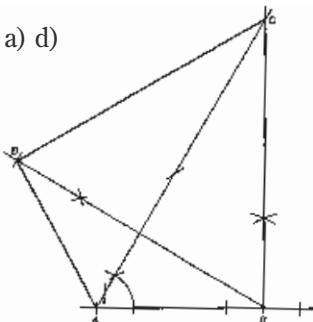

b) Satte av $AB = 9 \text{ cm}$. Konstruerte $\angle A = 60^\circ$ og $\angle B = 90^\circ$. Punkt C ligger i skjæringspunktet./Sette av $AB = 9 \text{ cm}$. Konstruerte $\angle A = 60^\circ$ og $\angle B = 90^\circ$. Punkt C ligg i skjæringspunktet.

c) $BC \approx 15,6 \text{ cm}$ $AC = 18 \text{ cm}$

e) Areal $\approx 140,4 \text{ cm}^2$

A 161

a) c)

d) $AE = 3,5 \text{ cm}$, $DE \approx 6,1 \text{ cm}$

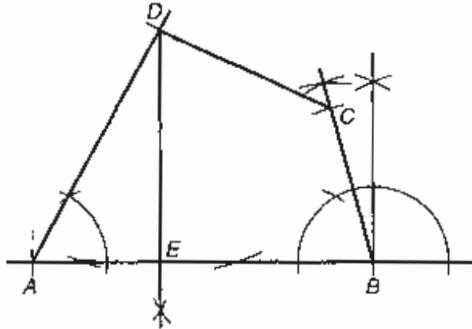

b) Satte av $AB = 9,0 \text{ cm}$. Konstruerte $\angle BAD = 60^\circ$ og satte av $AD = 7,0 \text{ cm}$.
 Konstruerte $\angle ABC = 75^\circ$ og satte av $BC = 4,2 \text{ cm}$. Trakk linjestykket CD .
 Sette av $AB = 9,0 \text{ cm}$. Konstruerte $\angle BAD = 60^\circ$ og satte av $AD = 7,0 \text{ cm}$.
 Konstruerte $\angle ABC = 75^\circ$ og satte av $BC = 4,2 \text{ cm}$. Drog linjestykket CD .

A 162

a)

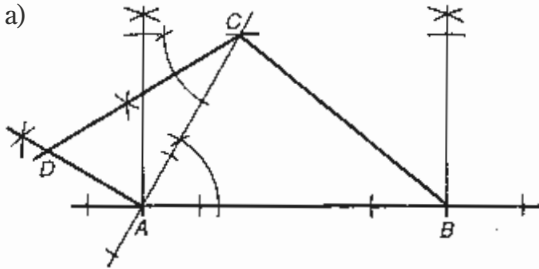

b) Satte av $AB = 8,0 \text{ cm}$. Konstruerte $\angle BAC = 60^\circ$. Konstruerte en parallell til AB i avstanden $4,5 \text{ cm}$. Punktet C ligger i skjæringspunktet mellom parallellen og det venstre vinkelbeinet til $\angle BAC$. Trakk linjen BC . Konstruerte $\angle CAD = 90^\circ$. Konstruerte $\angle ACD = 30^\circ$.
 Sette av $AB = 8,0 \text{ cm}$. Konstruerte $\angle BAC = 60^\circ$. Konstruerte ein parallell til AB i avstanden $4,5 \text{ cm}$. Punktet C ligg i skjæringspunktet mellom parallellen og det venstre vinkelbeinet til $\angle BAC$. Drog linja BC . Konstruerte $\angle CAD = 90^\circ$. Konstruerte $\angle ACD = 30^\circ$.

c) Areal $\approx 25,8 \text{ cm}^2$

Omkrets/Omkrins $\approx 24,0 \text{ cm}$

A 163

a) Ja. b)

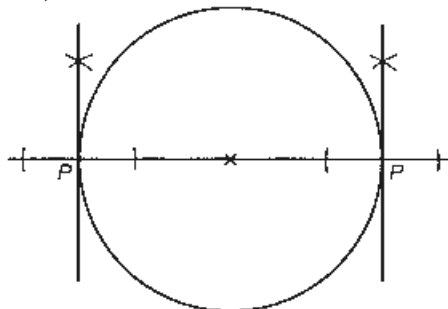

c) Tangentene står normalt på diameteren, og derfor er de parallelle.
 Tangentane står normalt på diameteren, og derfor er dei parallelle.

A 164

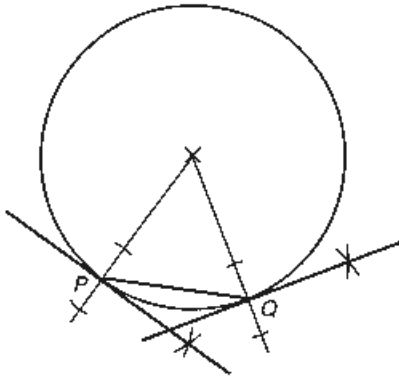

A 165

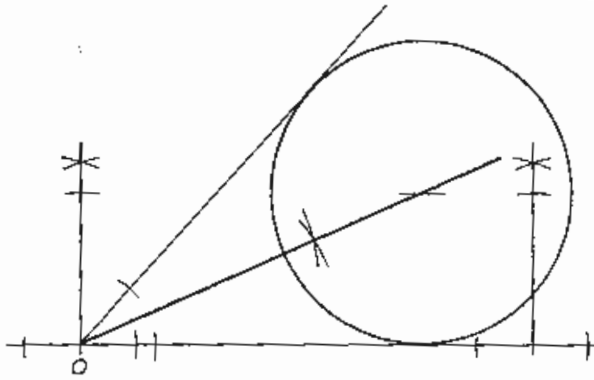

A 166

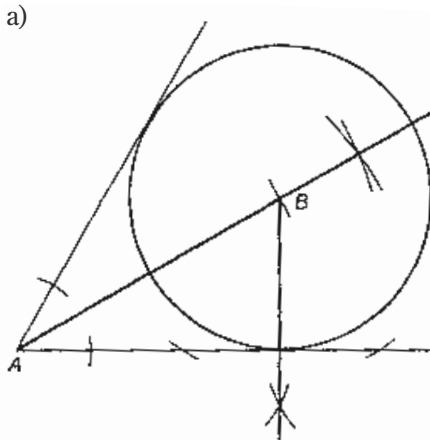

b) $r = 4,0$ cm

A 167

- a) $\approx 1,4$ cm
- b) $\approx 2,8$ cm
- c) diagonalen = $a \sqrt{2}$
- d) Alle diagonalene i kvadrater blir lik sidelengden multiplisert med $\sqrt{2}$.
Alle diagonalane i kvadrat blir lik sidelengda multiplisert med $\sqrt{2}$.

A 168

 $\approx 6,2 \text{ cm}^2$

A 169

a) d)

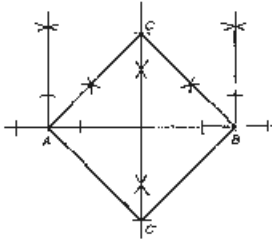

$\triangle ABC$ er en rettvinklet, likebeint trekant./
 $\triangle ABC$ er en rettvinkla, likebeint trekant.

b) $h = 4,3 \text{ cm}$ c) $A \approx 18,5 \text{ cm}^2$

e) Firkant $AC'BC$ er et kvadrat./Firkant $AC'BC$
 er eit kvadrat.

A 170

a)

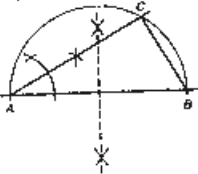

Dette er en trekant med vinkler på 30° , 60° og 90° . Vi
 setter av AB lik $8,0 \text{ cm}$ og konstruerer $\angle A = 30^\circ$ og
 $\angle B = 60^\circ$. Da får vi $\angle C = 90^\circ$./Dette er ein trekant med
 vinklar på 30° , 60° og 90° . Vi set av AB lik $8,0 \text{ cm}$ og
 konstruerer $\angle A = 30^\circ$ og $\angle B = 60^\circ$. Da får vi $\angle C = 90^\circ$.

b) Vi kan også starte med å konstruere $\angle C = 90^\circ$. Fordi dette er en trekant med
 vinkler på 30° , 60° og 90° , er BC halvparten av AC , altså $4,0 \text{ cm}$. Da kan vi sette
 av $CB = 4,0 \text{ cm}$ og $AB = 8,0 \text{ cm}$./Vi kan også starte med å konstruere $\angle C = 90^\circ$.
 Fordi dette er ein trekant med vinklar på 30° , 60° og 90° , er BC halvparten av
 AC , altså $4,0 \text{ cm}$. Da kan vi setje av $CB = 4,0 \text{ cm}$ og $AB = 8,0 \text{ cm}$.

A 171

Den lengste stanga er 9 m ./Den lengste stonga er 9 m .

A 172

a)

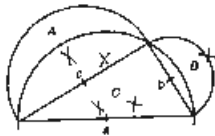
Vi skal bevise./Vi skal prove: $A + B = C$

Bevis/Prov:

$$A + B = \frac{\pi \cdot \frac{c}{2} \cdot \frac{c}{2}}{2} + \frac{\pi \cdot \frac{b}{2} \cdot \frac{b}{2}}{2} + \frac{bc}{2} - \frac{\pi \cdot \frac{a}{2} \cdot \frac{a}{2}}{2}$$

$$A + B = \frac{\pi c^2}{8} + \frac{\pi b^2}{8} + \frac{bc}{8} - \frac{\pi a^2}{8}$$

$$A + B = \frac{\pi}{8} (c^2 + b^2 - a^2) + \frac{bc}{2}$$

$$A + B = \frac{\pi}{8} (c^2 + b^2 - c^2 - b^2) + \frac{bc}{2}$$

$$A + B = \frac{bc}{2} = C$$

A 173

a) Vinklene er parvis like.

b) Lengden på samsvarende sider er ulikt.

A 174

- a) $\triangle ABC \sim \triangle ABE$ fordi
 $\angle ABC = \angle AEB = 90^\circ$
 A er felles i begge trekantene/er felles i begge trekantene
 Siden to av vinklene er parvis like store, er også det tredje parete like stort (vinkelsummen i en trekant er alltid 180°). Konklusjon: Fordi vinklene i trekantene er parvis like store, er trekantene formlike./Sidan to av vinklane er parvis like store, er også det tredje parete like stort (vinkelsummen i ein trekant er alltid 180°). Konklusjon: Fordi vinklane i trekantane er parvis like store, er trekantane formlike.
- b) $\triangle BEC \sim \triangle ABC$ fordi
 $\angle CEB = \angle CBA = 90^\circ$
 $\angle C$ er felles i begge trekantene/er felles i begge trekantane

A 175

- a) $\triangle ABC \sim \triangle AFB$ fordi
 $\angle ABC = \angle AFB = 90^\circ$
 $\angle BAF$ er felles i begge trekantene/er felles i begge trekantane
- b) $\triangle ACD \sim \triangle ADE$ fordi
 $\angle ADC = \angle AED = 90^\circ$
 $\angle DAC$ er felles i begge trekantene/er felles i begge trekantane
- c) 6

A 176

- a) Supplementvinkelen til $\angle a$ og $\angle b$ er samsvarende./Supplementvinkelen til $\angle a$ og $\angle b$ er samsvarande.
- b) L må være parallell med m .

A 177

- a) –
- b) $\angle a = \angle d = \angle e = \angle h$
 $\angle b = \angle c = \angle f = \angle g$
- c) $\angle a$ og $\angle e$ er samsvarende
 $\angle b$ og $\angle f$ er samsvarende
 $\angle c$ og $\angle g$ er samsvarende
 $\angle d$ og $\angle h$ er samsvarende

A 178

- a) De er toppvinkler./Dei er toppvinklar.
- b) De er samsvarende vinkler ved parallelle linjer./Dei er samsvarande vinklar ved parallelle linjer.
- c) De er samsvarende vinkler ved parallelle linjer./Dei er samsvarande vinklar ved parallelle linjer.
- d) $\triangle CDM \sim \triangle ABM$

A 179

- a) $\triangle ABC \sim \triangle DEC$ fordi
 $\angle BAC = \angle EDC$, samsvarende vinkler ved parallelle linjer er like store/
samsvarande vinklar ved parallelle linjer er like store
 $\angle BCA = \angle ECD$, felles i de to trekantene/felles i dei to trekantane
- b) $\triangle BGC \sim \triangle EFC$ fordi
 $\angle BGC = \angle EFC = 90^\circ$
 $\angle BCG = \angle ECF$, felles i de to trekantene/felles i dei to trekantane
- c) $\triangle AGC \sim \triangle DFC$ fordi
 $\angle AGC = \angle DFC = 90^\circ$
 $\angle ACG = \angle DCF$, felles i de to trekantene/felles i dei to trekantane

A 180

- $\triangle ABM \sim \triangle DMC$ fordi
 $\angle AMB = \angle DMC$, toppvinkler og like store/toppvinklar og like store
 $\angle ABM = \angle CDM$, samsvarende vinkler ved parallelle linjer/samsvarande vinklar ved parallelle linjer

A 181

- a) $DF = 8,0$ cm fordi trekantene er formlike og DE er dobbelt så lang som AB
b) 2 : 1 c) 1 : 2

A 182

- a) $x = 12,0$ cm b) $x = 3,0$ cm

A 183

- a) Likebeint trekant b) $BE = 2,5$ cm, $AE \approx 4,3$ cm
- c) $AB = BC = 0,5$ cm
Fordi trekantene er likebeinte, er $\angle BCE = \angle BAE = 30^\circ$ /Fordi trekantane er likebeinte, er $\angle BCE = \angle BAE = 30^\circ$
- d) $\triangle ABE \sim \triangle ACD$ fordi
 $\angle ADC = \angle AEB = 90^\circ$
 $\angle BAC = \angle ACD$ samsvarende vinkler ved parallelle linjer er like store/
samsvarande vinklar ved parallelle linjer er like store
- e) $AD \approx 4,3$ cm, $CD \approx 7,4$ cm f) Trapez g) $A \approx 26,7$ cm²

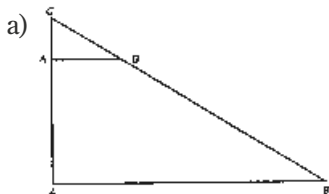
A 184

- b) $BC \approx 16,7$ cm
 $A'B' = 3,6$ cm, $A'C' = 2,1$ cm, $B'C' \approx 4,2$ cm
- c) Arealet av $\triangle ABC \approx 60,5$ cm²
Arealet av $\triangle A'B'C' \approx 3,8$ cm²
 $\frac{\triangle A'B'C'}{\triangle ABC} \approx 0,06$
- d) -

$\frac{\triangle A'B'C'}{\triangle ABC} = \frac{1}{4}$. Omkretsen reduseres i samme forhold som lengden av sidene./
Omkriksen blir redusert i same forhold som lengda av sidene.

A 189

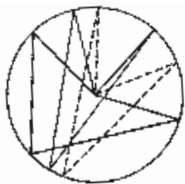

Sentralvinkelen er dobbelt så stor som periferivinkelen.

A 190

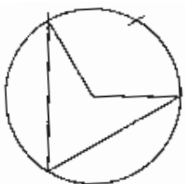

Periferivinkelen blir 60° .

A 191

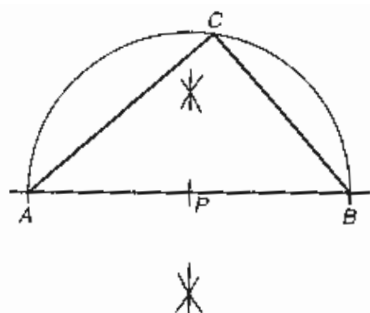

A 192

a) d)

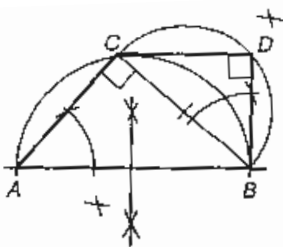

b) $BC \approx 4,5$ cm

c) Arealet $\approx 9,0$ cm²

e) $\triangle BCD \sim \triangle ABC$ fordi

$\angle ACB = \angle BDC = 90^\circ$

$\angle CAB = \angle CBD$ gitt i oppgaven, dermed er de to trekantene formlike/gitt i oppgåva, dermed er dei to trekantane formlike

f) $BD \approx 3,0$ cm, $CD \approx 3,4$ cm

g) Omkretsen/Omkrinsen $\approx 16,4$ cm

A 193

a) Arealet = $13,5$ cm²

b) $AB = 7,5$ cm

c) $\triangle ABC \sim \triangle CBF$ fordi

$\angle ACB = \angle CFB = 90^\circ$

$\angle B$ er felles i de to trekantene/felles i dei to trekantane

d) $CF = 3,6$ cm

A 194

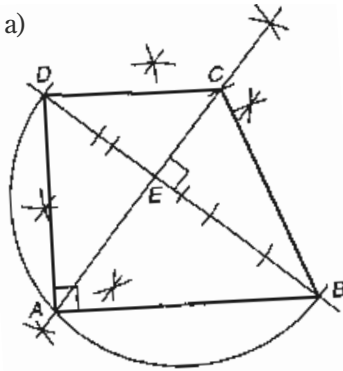

Konstruerte første diagonalene AC og BD normalt på hverandre. Satte av avstanden $EC = 2,7$ cm og deretter $CD = 4,5$ cm. Halverte DE og satte av $\frac{1}{2} DE$ tre ganger på diagonalen BE . Halverte BD og konstruerte en halvsirkel. A ligger da på skjæringen med halvsirkelen og AC . / Konstruerte først diagonalane AC og BD normalt på kvarandre. Sette av avstanden $EC = 2,7$ cm og deretter $CD = 4,5$ cm. Halverte DE og sette av $\frac{1}{2} DE$ tre gonger på diagonalen BE . Halverte BD og konstruerte ein halvsirkel. A ligg da på skjeringa med halvsirkelen og AC .

b) $DE = 3,6$ cm, $BC \approx 6,0$ cm, $BD \approx 9,0$ cm

c) $\triangle ABE \sim \triangle ADE$ fordi

$$\angle BEA = \angle AED = \angle BAD = 90^\circ$$

$\triangle ABD \sim \triangle AED$ fordi de har $\angle ADE$ felles/fordi dei har $\angle ADE$ felles

$\triangle ABD \sim \triangle AEB$ fordi de har $\angle ABE$ felles/fordi dei har $\angle ABE$ felles

$\triangle ABE$ er da formlik med $\triangle ADE$

d) $AE \approx 4,4$ cm

e) Arealet $\approx 32,0$ cm²

A 195

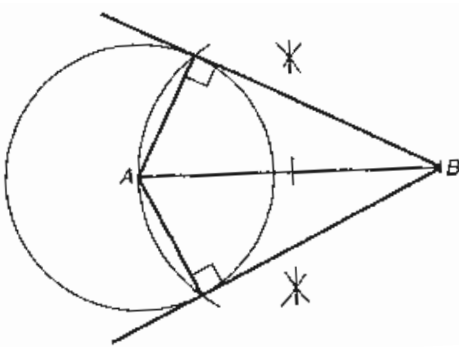

A 196

a) b)

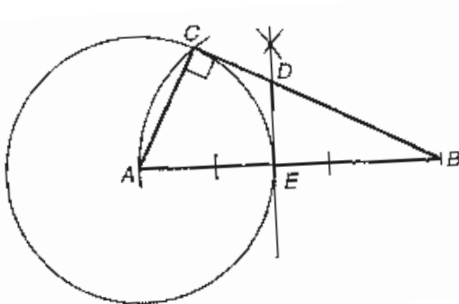

c) $\triangle ABC \sim \triangle DBE$ fordi

$$\angle BED = \angle BCA = 90^\circ$$

$\angle B$ er felles i de to trekantene/er felles i dei to trekantane

$$BC \approx 6,9 \text{ cm } DE \approx 2,3 \text{ cm}$$

d) Arealet $\approx 13,8$ cm²

A 197

- a) $A = 11,2 \text{ cm}^2$ b) $A = 63,8 \text{ cm}^2$

A 198

- a) $O = 25,1 \text{ cm}$ b) $\approx \frac{2}{5}$ c) $\approx \frac{2}{5}$ d) $= 20,1 \text{ cm}^2$

A 199

- a) $A \approx 24,0 \text{ cm}^2$ b) $A \approx 24,0 \text{ cm}^2$ c) $A \approx 479,3 \text{ cm}^2$

A 200

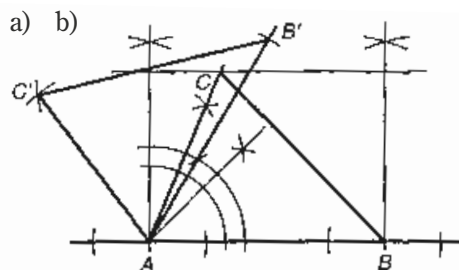

A 201

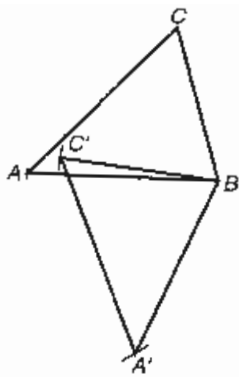

A 202

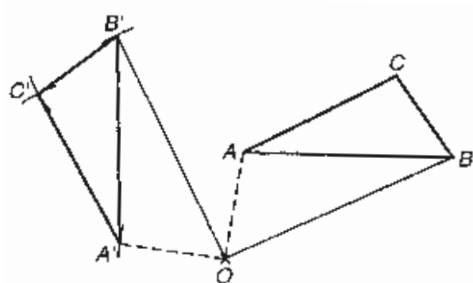

A 203

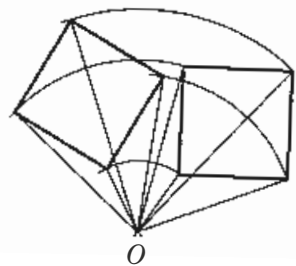

A 204

- a) Sentrum i sirkelen.
b) Skjæringspunktet mellom diagonalene./Skjæringspunktet mellom diagonalane.
c) Skjæringspunktet mellom diagonalene./Skjæringspunktet mellom diagonalane.

PRØV DEG SELV

PA 1

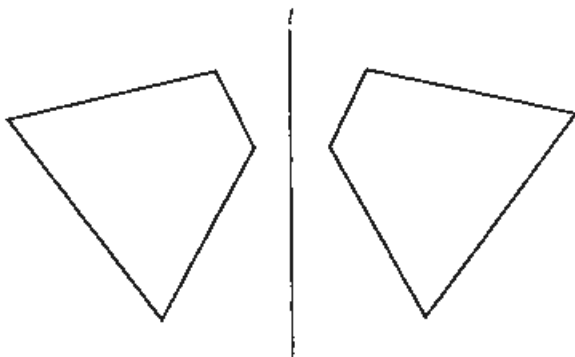

PA 2

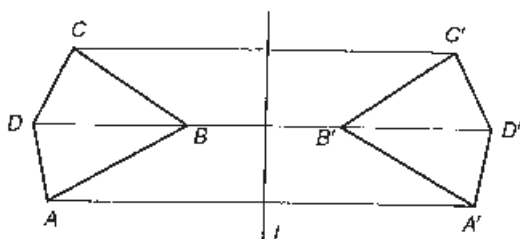

PA 3

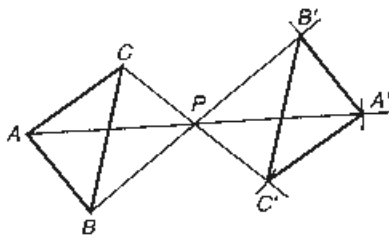

PA 4

a)

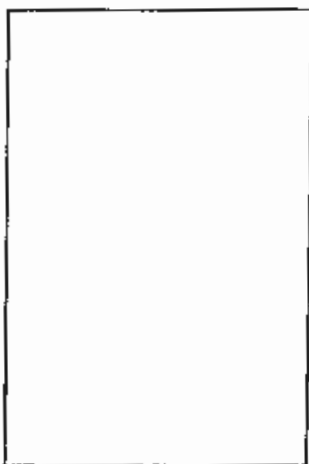

b)



Rutestørrelsen er
 $0,5 \text{ cm} \cdot 0,5 \text{ cm}.$
Rutestørleiken er
 $0,5 \text{ cm} \cdot 0,5 \text{ cm}$

PA 5

- a) 500 m b) 3250 m

PA 6

- a) $\approx 31,2 \text{ cm}^2$ b) $\approx 12\,471 \text{ m}^2$

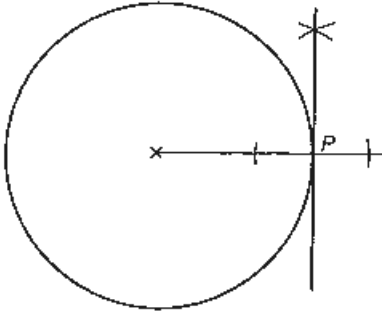
PA 7**PA 8**

– Bruk formlikhet.

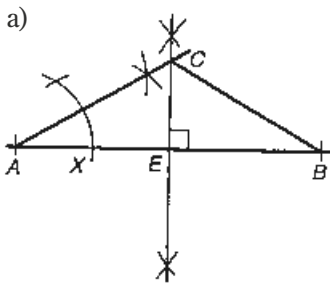
PA 9

- a) b) Likebeint trekant fordi $AC = BC$.
 c) $\angle C = 120^\circ$
 d) Dette er en trekant med vinkler på 30° , 60° og 90° , og da er hypotenusen dobbelt så lang som den korteste kateten./Dette er ein trekant med vinklar på 30° , 60° , og 90° , og da er hypotenusen dobbelt så lang som den kortaste kateten.
- e) Vi bruker den pytagoreiske læresetninga./Vi bruker den pytagoreiske læresetninga:
 $(AC)^2 = (CE)^2 + (AE)^2$
 $(2x)^2 = x^2 + 4^2$
 $4x^2 = x^2 + 16$
- f) $AC \approx 4,6 \text{ cm}$
 g) Arealet $\approx 9,2 \text{ cm}^2$

PA 10

- a) $\triangle ABC \sim \triangle DBA$ fordi
 $\angle BAC = \angle ADB = 90^\circ$
 $\angle B$ er felles i de to trekantene/er felles i dei to trekantane
- b) $BC \approx 6,3 \text{ cm}$ $AC \approx 3,8 \text{ cm}$
- c) Arealet av $\triangle ABC \approx 9,5 \text{ cm}^2$
 Arealet av $\triangle ABD = 6,0 \text{ cm}^2$

PA 11

Arealet $\approx 24,0 \text{ cm}^2$

LANDOPPGAVE: SVERIGE

LA 1

a)

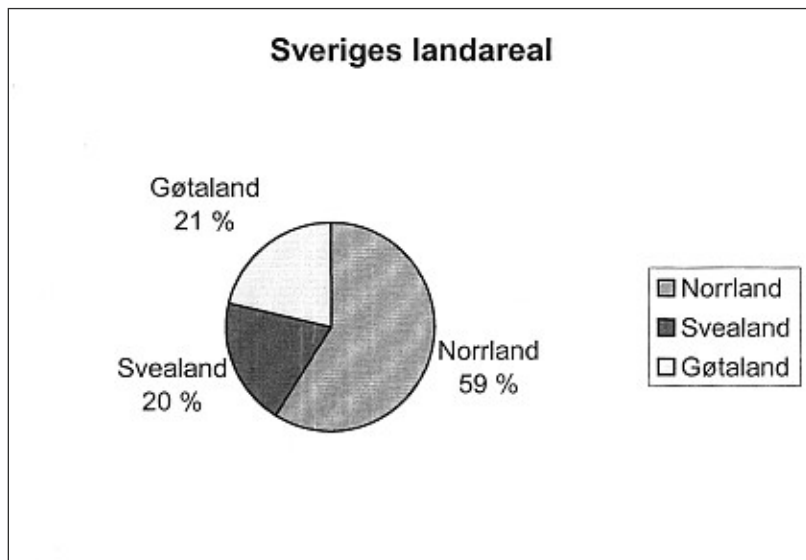

b) Gøtaland 4,4 millioner Svealand 3,5 millioner Norrland 1,3 millioner

LA 2

a)

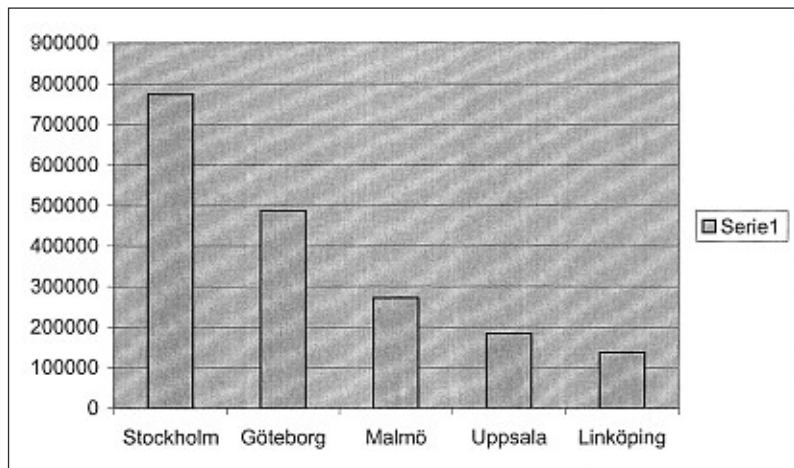

b) 1 855 000

c) 20,4 %

d) 59 %

LA 3	a) 25 år e) $\approx 3,7\%$	b) 487 år (i 2008) f) $\approx 24,4$ km/t	c) 1 312 572 km	d) ca. 33 ganger
LA 4	e) 90,9 %	f) $1,32 \cdot 10^7$ tonn		
LA 5	a) 1826	b) 2 timer 12 min	c) 1889	d) –
LA 6	a) 60	b) 161 000		
LA 7	75 g margarin 3 dl melk 3/4 pk gjær 3/4 dl sukker 7,5 dl hvetemel 1,5 ts	LA 8	a) 42,75 km/t	b) 11,9 m/s
LA 9	5,98 millioner NOK	LA 10	7,5 dager	
LA 11	31 400 m ² \approx 4 fotballbaner			
LA 12	a) ≈ 28 m	b) ≈ 10 m		
LA 13	1560 m	LA 14	6 à 2,50 kr	3 à 1,80 kr
LA 15	a) $d_1 = \frac{2A}{d_2}$	b) $d_1 = 7$ cm		

FASIT TIL KAPITTEL B

TALL OG ALGEBRA

B 1

- a) $13a$ b) $4a$ c) $8a - 2b$ d) $3a + 5b$
e) $9a + 3b - c$ f) $a + 12$ g) $a + 2b + 1$ h) $7a - 10b - 5$

B 2

- a) $7x + 3$ b) $3x - 3$ c) $3x + 3$ d) $14a + 14b$
e) $34a + 10b + 11c$ f) $9 - 9a$

B 3

$15x + 3$ er riktig svar.

Minus og minus gir pluss. Ola endret ikke fortegnet da han løste opp den siste parentesen./

$15x + 3$ er rett svar.

Minus og minus gir pluss. Ola endra ikkje forteiknet da han løyste opp den siste parentesen.

B 4

- a) $5a + 15$ b) $8a + 12$ c) $3x + 30$ d) $40a + 64$
e) $8a - 12b$ f) $15x - 6y$ g) $18b - 36c$ h) $-8x - 12$
i) $-8a + 4$ j) $-28x + 14y$ k) $-10z^2 + 15z$ l) $-16a^2 + 24ab$

B 5

- a) $5x + 15$ b) $3x - 15$ c) $-2x - 6$ d) $-3x + 9$
e) x^2 f) $2x^2$ g) $2x^2 + 10x$ h) $6x^2 - 8x$
i) $5a^2 + 15a$ j) $14g^2 + 28g$ k) $-2a^2 - 8a$ l) $5a^2 - 35a$
m) $6x^2 + 10x$ n) $8a^2 + 4ab$ o) $-ba^2b - 9ab$

B 6

- a) $x^2 + 9x + 20$ b) $x^2 + 8x + 12$ c) $a^2 + 12a + 32$
d) $y^2 + 12y + 27$ e) $x^2 + 4x + 3$ f) $x^2 + 7x + 12$

B 7

- a) $6x^2 + 22x + 20$ b) $2x^2 + 5x + 3$ c) $4x^2 + 13x + 3$
d) $18x^2 + 18x + 4$ e) $10x^2 + 27x + 18$ f) $6x^2 + 11x + 4$
g) $63x^2 + 52x + 5$ h) $3x^2 + 46x + 120$

B 8

- a) $x^2 - x - 2$ b) $2x^2 + 3x - 2$ c) $4x^2 + 11x - 3$
d) $2x^2 + 6x - 20$ e) $5x^2 - 34x - 7$ f) $7x^2 - 61x - 18$

B 9

- a) $2x^2 + x - 3$ b) $x^2 - x - 12$ c) $x^2 + 2x - 15$
d) $15x^2 - 7x - 2$ e) $21x^2 - x - 2$ f) $6x^2 - 50x - 36$

B 10

- a) $x^2 - 3x + 2$ b) $x^2 - 10x + 24$ c) $x^2 - 17x + 72$ d) $x^2 - 9x + 14$
 e) $15x^2 - 13x + 2$ f) $4x^2 - 13x + 10$ g) $48x^2 - 38x + 5$ h) $4x^2 - 12x + 9$
 i) $25x^2 - 20x + 4$ j) $63x^2 - 41x + 6$

B 11

- a) $15x^2 - 39x - 18$ b) $56x^2 + 18x - 8$ c) $6x^2 - 26x + 28$ d) $x^2 + 11x + 24$

B 12

Fortegnet foran $6x \cdot 5$ skal være pluss./Forteiknet føre $6x \cdot 5$ skal vere pluss.

B 13

- a) $x^2 + 10x + 25$ b) $x^2 + 8x + 16$ c) $x^2 - 6x + 9$ d) $x^2 - 14x + 49$
 e) $4x^2 + 12x + 9$ f) $25x^2 - 30x + 9$ g) $25x^2 + 80x + 64$ h) $16x^2 - 64x + 64$
 i) $36x^2 + 120x + 100$

B 14

- a) $x^2 + 17x + 27$ b) $3x^2 + 21x + 28$ c) $16x^2 + 52x + 41$ d) $18x^2 + 59x + 40$
 e) $10x^2 + 37x + 16$ f) $28x^2 + 49x + 21$ g) $21x^2 - 5x - 8$ h) $3x^2 - x$
 i) $3x^2 + 4x - 1$ j) $5x^2 + 13x + 2$

B 15

- a) $-3x^2 + 10x + 2$ b) $-4x + 1$ c) $x^2 - 2x - 5$ d) $x^2 - 7x - 4$
 e) $-x^2 + 5x - 2$ f) $8x + 8$

B 16

Feil 1: $15x^2 - 2 \cdot 3x + 2 \cdot 4 - (x \cdot 2x - 4 \cdot 3 + 2x - 3 \cdot 4) =$
 Feil 2: $15x^2 - 6x + 8 - 2x^2 - 4x - 6x + 12$

Når parentesen med minus løses opp, må alle fortegn endres. Her er ikke + 2 endret til - 2 og - 4x er ikke endret til + 4x./ Når parentes med minus føre blir løyst opp, må vi endre alle forteikna. Her er ikkje + 2 endra til - 2 og - 4x er ikkje endra til + 4x.

B 17

- a) 8 b) -34 c) 7

B 18

- a) $2a + 4b + 2c$ b) 48 cm c) 56 cm

B 19

- a) $\frac{6}{7}$ b) $\frac{12}{11} = 1\frac{1}{11}$ c) $\frac{7}{10}$ d) $\frac{11}{42}$ e) $\frac{10}{13}$ f) $2\frac{4}{7}$
 g) $\frac{6}{35}$ h) $\frac{2}{7}$ i) $\frac{5}{9}$

B 20

Seghen 496 kr Ali 620 kr Anne 124 kr

B 21

Arnt måker 18 m./Arnt mokar 18 m.

B 22

10 g gjær
 2 dl vann/vatn
 4 dl rugmel/rugmjøl
 1,5 dl hvetemel/kveitemjøl
 1 ts salt

B 23

Mons 993,50 kr

Ole 903,20 kr

Kirsten 1264,50 kr

Randi 1038,70 kr

B 24

a) $2 \cdot 5 \cdot x \cdot y$

c) $2 \cdot 2 \cdot 2 \cdot y \cdot y$

e) $2 \cdot 2 \cdot 2 \cdot 2 \cdot 2 \cdot a \cdot a \cdot b$

g) $2 \cdot 2 \cdot 2 \cdot 7 \cdot x \cdot y \cdot y$

b) $x \cdot x \cdot y$

d) $2 \cdot 2 \cdot 3 \cdot x \cdot x \cdot y \cdot y \cdot y$

f) $2 \cdot 2 \cdot 2 \cdot 2 \cdot 3 \cdot x \cdot y \cdot y$

h) $2 \cdot 7 \cdot x \cdot x \cdot x \cdot y$

B 25

a) $2y$

b) $\frac{x}{2}$

c) $\frac{7 \cdot ab}{3}$

d) $\frac{3xy}{5}$

e) $\frac{a}{3b}$

f) $\frac{y}{3x}$

g) $\frac{3ab}{2}$

h) $\frac{1}{2xy}$

B 26

a) $\frac{9}{a}$

b) $\frac{9x}{7}$

c) $\frac{7}{ab}$

d) $\frac{13}{6x^2y}$

e) $\frac{3}{a^2}$

f) $\frac{7x + 15y}{13}$

B 27

a) $\frac{13x}{12}$

b) $\frac{7}{6x}$

c) $\frac{x}{4}$

d) $\frac{19a}{42b}$

e) $\frac{41x}{180}$

B 28

a) $\frac{5x + 9}{3}$

b) $\frac{8a + 3b}{7}$

c) $\frac{4x + 4}{11}$

d) $\frac{2a + 9b}{ab}$

B 29

a) $\frac{2y}{3x}$

b) 1

c) $\frac{4y}{3}$

d) $\frac{20ax}{3by^3}$

e) $\frac{3b}{5a}$

f) $\frac{4xy}{ab^2}$

g) $\frac{8b}{a^2}$

h) $\frac{ax}{6}$

B 30

a) $9y$

b) $10x$

c) $9a$

d) $10b$

e) $13x$

f) $26y$

B 31

a) $6a$

b) $8y$

B 32

-

B 33

Kaller vi lengden av det korteste røret a , vil den totale lengden av rørene bli $7a$. / Kallar vi lengda av det kortaste røret a , blir den samla lengda av røra $7a$.

B 34

a) $4x$

b) $9y$

c) $13x$

d) $6a$

e) $8b$

f) $5c$

B 35

a) $4x + 6y$

b) $8a + 6b$

c) $2a + 2b$

d) $y + 2x$

e) $6a - 3b - 6y$

f) $8c + 2d$

B 36

a) $14a + 8b, 52$

b) $4a + 10b, 38$

c) $4a - 3b, -1$

d) $a - 2b, -4$

e) $b, 3$

f) $-a + b, 1$

B 37

I en parentes med plusstegn foran beholder vi fortegnene inne i parentesen uendret./I ein parentes med plussteikn føre skal vi ikkje endre forteikna inne i parentesen.

B 38

a) $6a + 3b$ b) $8x - 2y$ c) $7x - y$ d) $5a - 8b$

B 39

-

B 40

I en parentes med minustegn foran må vi endre fortegnene inne i parentesen når den løses opp./I ein parentes med minusteikn føre må vi endre forteikna inne i parentesen når vi løyser han opp.

B 41

a) $4x - 3y$ b) $10a - 3b$ c) $-a + 3b$ d) $3a + 4b$

B 42

a) $3x + y$ b) $x - 2y + 2$ c) 0 d) $-6x - 2y + 1$

B 43

-

B 44

$$\begin{aligned} \text{a) } 4x - (3y + 2x) + (3x - y) &= \\ 4x - 3y - \underline{2x} + 3x - \underline{y} &= \\ 5x - 4y & \end{aligned}$$

$$\begin{aligned} \text{b) } 5a - (-3a + 4b) + (3a - b) &= \\ 5a + \underline{3a} - 4b + 3a - b &= \\ 11a - 5b & \end{aligned}$$

$$\begin{aligned} \text{c) } -2x + 2y - (3x - y) + (2x - 4y) &= \\ -2x + 2y - \underline{3x} + y + 2x - 4y &= \\ -3x - y & \end{aligned}$$

B 45

-

B 46

a) $12x + 18$ b) $21y - 35$ c) $42a + 56$ d) $48b - 64$
e) $20x^2$ f) $-12x + 27$

B 47

a) $12x^2 + 21x$ b) $28y^2 - 12y$ c) $-30a^2 + 10a$ d) $-42x^2 - 30x$
e) $30x^2 + 15x$ f) $12y^2 - 18y$

B 48

Understrekingene viser hvor feilene er./Understrekingane viser kvar feila er.

a) $4x \cdot (2x - 3) = 4x \cdot 2x - 4x \cdot 3 = \underline{8x^2} - 12x$

b) $3y(-2y + 4) = 3y \cdot \underline{(-2y)} + 3y \cdot 4 = -6y^2 + 12y$

c) $-4a(2a - 3) = -4a \cdot 2a + \underline{4a \cdot 3} = -8a^2 + 12a$

d) $-4x(-5x + 2) = \underline{4x \cdot 5x} - 4x \cdot 2 = 20x^2 - 8x$

B 49

-

B 50

a) $3x^2 + 27x + 20$

b) $24y^2 + 54y + 27$

c) $6y^2 + 60y + 54$

d) $18x^2 + 73x + 35$

B 51

Understrekningene viser hvor feilene er./Understrekingane viser kvar feila er.

$(4x + 3)(2x + 7) =$

$4x \cdot 2x + 4x \cdot 7 + 3 \cdot 2x + 3 \cdot 7$

$\underline{8x^2} + \underline{28x} + \underline{6x} + 21 =$

$8x^2 + 34x + 21$

B 52

-

B 53

a) $20x^2 - x - 12$

b) $4x^2 + 25x - 21$

c) $15x^2 + 18x - 24$

d) $24x^2 - 16x - 30$

e) $12y^2 - 13y - 35$

f) $30x^2 - 22x - 28$

B 54

a) $8x^2 + 10x - 3$

b) $7x^2 + 20x - 30$

c) $11x^2 - 21x - 6$

d) $25x^2 + 57x - 5$

B 55

Understrekningene viser hvor feilene er./Understrekingane viser kvar feila er.

$(4x - 7)(3x + 2) + (2x + 3)(6x - 2) + 7 =$

$4x \cdot 3x + 4x \cdot 2 - 7 \cdot 3x - 7 \cdot 2 + 2x \cdot 6x \underline{-2x \cdot 2} + 3 \cdot 6x - 3 \cdot 2 + 7 =$

$\underline{12x^2} + 8x - 21x - 14 - 12x^2 - 4x + 18x - 6 + 7 =$

$24x^2 + x - 13$

B 56

-

B 57

Understrekningene viser hvor feilene er./Understrekingane viser kvar feila er.

$2x^2 + (3x - 2)(x + 6) + (4x + 5)(3x - 2) =$

$2x^2 + 3x \cdot x + 3x \cdot 6 \underline{-2 \cdot x} - 2 \cdot 6 + 4x \cdot 3x \underline{-4x \cdot 2} + 5 - 3x \cdot 2 =$

$2x^2 + 3x^2 + 18x \underline{-2x} - 12 + 12x^2 \underline{-8x} + 15x - 10 =$

$17x^2 + 23x - 22$

B 58

a) 24 cm

b) 40 cm

c) 34 cm

d) 3 m

B 59

a) 32 cm

b) 22 dm

c) 22 m

d) 63 m

B 60

a) $3a + 2b$

b) 16 cm

B 61

a) $4a + 4b$

b) 200 m

B 62

-

B 63

a) 29

b) 47

c) 38

B 64

a) 35

b) 21

c) 42

B 65

- a) Samlet pris på 4 appelsiner og 5 epler./Samla pris på 4 appelsinar og 5 eple.
b) 23 kr

B 66

- a) $10a + 6b + 8c$ b) 38 kr

B 67

- a) $\frac{5}{7}$ b) $\frac{5}{11}$ c) $\frac{13}{19}$ d) $\frac{3}{13}$ e) $\frac{-4}{17}$ f) 0

B 68

- a) $\frac{2}{b}$ b) $\frac{x}{3y}$ c) $\frac{x}{2y}$ d) $\frac{1}{2x}$ e) $2b$ f) $\frac{1}{2b}$
g) $\frac{1}{4x}$ h) $4x$

B 69

- a) $\frac{1}{3a}$ b) $3a$ c) $\frac{6}{5y}$ d) $\frac{3}{5}$ e) $\frac{2y}{3x}$ f) $\frac{1}{3x}$
g) $\frac{2}{3x}$ h) $\frac{3}{2a}$

B 70

- a) $\frac{10}{x}$ b) $\frac{9y}{x}$ c) $\frac{4}{x^2}$ d) $\frac{0}{17} = 0$ e) $\frac{3}{xy}$ f) $\frac{1}{2ab}$

B 71

- a) $\frac{8}{27}$ b) $\frac{15}{16}$ c) $\frac{3}{40}$ d) $\frac{8}{27}$

B 72

- a) $\frac{1}{6}$ b) $\frac{1}{3}$ c) $1\frac{4}{5}$ d) $\frac{2}{5}$

B 73

- a) $3\frac{1}{3}$ b) $1\frac{1}{5}$ c) $1\frac{1}{5}$ d) $1\frac{1}{3}$

B 74

- a) $\frac{4}{5}$ b) 6 c) 1 d) $\frac{1}{2}$

B 75

- a) $2\frac{1}{4}$ b) $16\frac{1}{3}$ c) $4\frac{1}{2}$

B 76

- a) $2\frac{1}{2}$ b) $1\frac{1}{3}$ c) $\frac{9}{10}$

B 77

- a) $\frac{2}{9}$ b) $\frac{5}{21}$ c) $7\frac{1}{2}$

B 78

- a) $\frac{6}{7}$ b) $\frac{2}{11}$ c) $\frac{1}{13}$

B 79	a) $\frac{14}{3}$	b) $\frac{30}{9}$	c) $\frac{37}{8}$	d) $\frac{45}{7}$		
B 80	a) $1\frac{3}{5}$	b) 3	c) $6\frac{4}{5}$	d) $6\frac{1}{6}$		
B 81	a) $\frac{3}{5} = \frac{6}{10} = \frac{9}{15} = \frac{12}{20}$	b) $\frac{2}{7} = \frac{4}{14} = \frac{6}{21} = \frac{8}{28}$				
	c) $\frac{2}{3} = \frac{4}{6} = \frac{6}{9} = \frac{8}{12}$	d) $\frac{3}{4} = \frac{6}{8} = \frac{9}{12} = \frac{12}{16}$				
B 82	a) 4	b) 21	c) 7	B 83 a) 1 b) 2		
B 84	a) $\frac{1}{3}$	b) $\frac{1}{4}$	c) $\frac{2}{3}$	B 85 40 kg		
B 86	a) $\frac{11}{14}$	b) $\frac{7}{12}$	c) $2\frac{2}{5}$	B 87 a) $\frac{3}{5y}$ b) $\frac{2b}{3a}$		
B 88	a) $\frac{6}{35}$	b) $1\frac{3}{7}$	c) $1\frac{2}{3}$	B 89 60 kr		
B 90	$11\frac{1}{3}$ liter	B 91	a) 4 000 kr	b) 2 000 kr		
B 92	a) $1\frac{1}{3}$	b) $2\frac{11}{12}$	c) $2\frac{6}{7}$	B 93 $24\frac{5}{6}l$		
B 94	a) $1\frac{1}{4}$ kg	B 95	a) $\frac{1}{4}$	b) $\frac{3}{4}$		
B 96	a) $\frac{1}{2}$	b) $\frac{3}{10}$	c) $\frac{4}{10} = \frac{2}{5}$	d) $\frac{3}{4}$	e) $\frac{1}{2}$	f) $\frac{7}{10}$
	g) $\frac{1}{3}$	h) $\frac{1}{4}$	i) $\frac{2}{25}$	j) $\frac{1}{50}$	k) $\frac{1}{4}$	l) $\frac{7}{1000}$
B 97	a) 51	b) 19	c) 1	d) - 13	e) - 20	f) - 44

B 98

Med plusstegn foran parentesen beholdes fortegnene uendret når parentesen løses opp. Med minustegn foran parentesen må vi endre fortegnene inne i parentesen når den løses opp./Med plussteikn føre parentesen endrar vi ikkje forteikna når vi løyer opp parentesen. Med minusteikn føre parentesen må vi endre forteikna inne i parentesen når vi løyer han opp.

B 99

- a) $7x + 3$ b) $y - 3$ c) $-x - 1$ d) $-a + 5$ e) $5x - 1$
 f) $4z + 5$ g) $2b - 4$ h) $2y + 7$ i) $7x + 4$ j) $3x + 6$
 k) $-3a$ l) 0 m) $-x - y$ n) $18x$

B 100

- a) $-10x^2 - 15x$ b) $-6x^2 + 4x$ c) $-9x^2 - 9x$ d) $12x^2 + 12x$
 e) $10x^2 + 15x$ f) $6x^2 - 4x$

Svaret i oppgave b) er feil./Svaret i oppgave b) er feil.

B 101

-

B 102

- a) $-21x^2 - 36x$ b) $y^2 - 14y$ c) $a^2 + 23a$ d) $b^2 + 14b - 6$

B 103

- a) $x^2 + 10x + 24$ b) $y^2 + 16y + 63$ c) $8x^2 + 18x + 9$ d) $30y^2 + 71y + 42$
 e) $28a^2 + 74a + 48$ f) $12a^2 + 50a + 48$

B 104

-

B 105

- a) $x^2 - x - 6$ b) $6x^2 - 40x - 14$ c) $20x^2 - 3x - 9$ d) $30y^2 + 9y - 12$
 e) $15y^2 + 14y - 49$ f) $72y^2 - y^2 - 56$

B 106

- a) $x^2 - 11x + 30$ b) $x^2 - 13x + 36$ c) $2x^2 - 20x + 32$ d) $4x^2 - 37x + 40$
 e) $18y^2 - 45y + 28$ f) $-48x^2 + 98x - 49$

B 107

- a) $-36y^2 + 72y - 35$ b) $-48x^3 + 42x^2 + 48x - 42$
 c) $-4a^3 + 10a^2 - 10a + 25$ d) $12x^4 - 39x^2 + 30$

B 108

- a) $x^2 + 8x + 16$ b) $x^2 - 10x + 25$
 c) $16y^2 - 48y + 36$ d) $4a^4 + 16a^3 + 16a^2$

B 109

Understrekingen viser hvor feilene er./Understrekinga viser kvar feila er.

$$5x^2 - (2x - 6)^2 + (2x - 3)(x + 4) =$$

$$5x^2 - (2x - 6)(2x - 6) + (2x - 3)(x + 4) =$$

$$5x^2 - (2x \cdot 2x - 2x \cdot 6 - 6 \cdot 2x + 6 \cdot 6) + (2x \cdot x + 2x \cdot 4 - 3 \cdot x - 3 \cdot 4) =$$

$$5x^2 - 4x^2 + 12x + \underline{12x - 36} + 2x^2 + 8x - 3x - 12$$

$$3x^2 + 29x - 48$$

B 110

- a) $18y^2 + 55y + 42$ b) $17x^2 + 44x + 21$
 c) $16y^2 + 47y + 15$ d) $14x^2 - 5$
 e) $-8a^2 + 4a + 9$ f) $20b^2 - 30b + 25$

B 111

a) $-2x^2 + 11x + 3$

b) $-15x + 15$

c) $-18x^2 + 13x + 5$

d) $12x^2 + 33x + 5$

e) $-29y^2 - y - 7$

f) $17y^2 + 13y + 7$

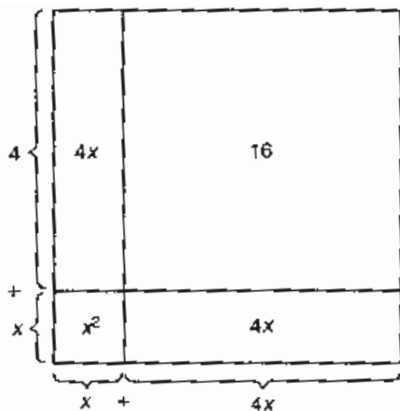
B 112

$x^2 + 4x + 4x + 16 = x^2 + 8x + 16$

$(x + 4)^2 = x^2 + 8x + 16$

Svaret blir det samme./Svaret blir det same.

B 113

a) $x^2 + 4x + 4$

b) $x^2 + 14x + 49$

c) $x^2 + 18x + 81$

d) $4x^2 + 20x + 25$

e) $9x^2 + 36x + 36$

f) $25x^2 + 10x + 1$

g) $16x^2 + 16x + 4$

h) $36x^2 + 36x + 9$

B 114

$a = 9, b = 5, c = 7, d = 8$

B 115

-

B 116

a) $30,96 \text{ cm}^2$

b) $62,135 \text{ dm}^2$

c) $3,1046 \text{ m}^2$

B 117

a) -4

b) -55

c) 79

B 118Multipliserer uttrykket $a = \frac{3b}{4}$ med $\frac{4}{3}$ **B 119**

$\frac{1}{\pi} \cdot A = \pi \cdot r^2 \cdot \frac{1}{\pi} \quad r^2 = \frac{1}{\pi} \Rightarrow r = \frac{\sqrt{A}}{\pi}$

B 120

a) $6x + 2y$

b) 27 cm

c) $x^2 + 2xy$

d) 26 cm^2

B 121

a) Arealet: $\frac{a \cdot b}{2}$

Omkretsen:/Omkrinsen. $a + b + c$

b) 12 cm^2

B 122

a) 61 stolper/stolpar

b) 180 m

c) $61x + 180y$

d) 784 kr

e) Ibrar 342 kr, Benedikte 442 kr

B 123

-

B 124

a) $\frac{16}{21}$ b) $4\frac{2}{15}$ c) $1\frac{5}{6}$ d) $\frac{32}{35}$ e) $-\frac{7}{20}$ f) $1\frac{5}{8}$

B 125

a) $\frac{x}{2y}$ b) $\frac{x}{8y}$ c) $\frac{x}{3y}$ d) $\frac{2}{3}$ e) $\frac{2}{x}$ f) $\frac{1}{2}$
 g) 2 h) $\frac{2x}{3y}$

B 126

a) $\frac{1}{2x}$ b) $\frac{1}{4z}$ c) $\frac{2c}{3a}$ d) $\frac{30}{19xy}$ e) $\frac{1}{3x}$ f) 2
 g) 9 h) $\frac{1}{3}$ i) $\frac{2y}{5x^2}$

B 127

a) $\frac{11}{y}$ b) $\frac{1}{x}$ c) $\frac{1}{y^2}$ d) 0 e) $\frac{5}{x+1}$ f) $\frac{a}{2a+b}$

B 128

a) $\frac{3}{10}$ b) $3\frac{1}{3}$ c) 1 d) $12\frac{1}{3}$ e) $\frac{4}{5}$ f) $5\frac{5}{8}$

B 129

a) -17 b) -36 c) -9 d) 19

B 130

Med plusstegn foran parentesen beholdes fortegnene uendret når parentesen løses opp. Med minustegn foran parentesen må vi endre fortegnene inne i parentesen når den løses opp./Med plussteikn føre parentesen endrar vi ikkje forteikna når vi løyser opp parentesen. Med minusteikn føre parentesen må vi endre forteikna inne i parentesen når vi løyser han opp.

B 131

a) $9x - 10y$ b) $-12a - b + 4c$ c) $14c - 7d - 3e$

B 132

a) $3x - 15$ b) $12x^3$ c) $-8a^2 + 10a$ d) $5x^3 - 35x^2$
 e) $-5x^3 - 6x^2$ f) $-4b^3 + 6b^2$

B 133

a) $-a^2 - 11a + 15$ b) $-19x^2 + 29x$ c) $-29b^2 + 31b$
 d) $2x^2 + 9x - 6y$

B 134

a) $x^2 + 9x + 18$ b) $12x^2 + 28x + 15$ c) $-4y^2 - 33y + 27$
 d) $4a^2 - 24a + 36$ e) $-12x^2 + 16x + 28$ f) $y^4 + 10y^2 + 25$
 g) $-18a^2 + 33a - 12$ h) $16x^2 - 9$

B 135

a) $-2x^2 - 35x + 12$ b) $-26x^2 - 10x + 20$ c) $11y^2 - 40y + 30$
 d) $7y^2 - 18y$

B 136

- a) $-32a^3 + 87a^2 - 48a$
 c) $17y^3 + 108y^2 + 84y$
 e) $-40y^3 + 6y^2 + 63y - 40$

- b) $-60x^3 - 58x^2 + 40x$
 d) $32x^3 + 84x^2 + 80x$
 f) $24x^3 - 55x^2 + 12x - 25$

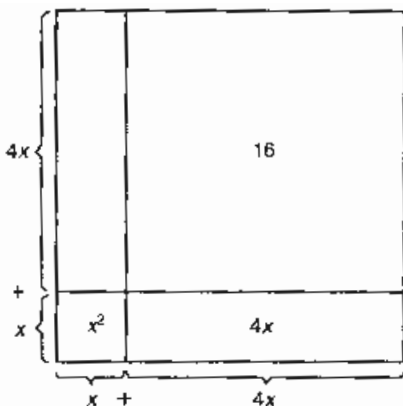
B 137

$$x^2 + 4x + 4x + 16 = x^2 + 8x + 16$$

$$(x + 4)^2 = x^2 + 8x + 16$$

Svaret blir det samme./Svaret blir det same.

B 138

- a) $x^2 + 4x + 4$
 d) $4x^2 + 24x + 36$
 g) $81x^2 + 108x + 36$

- b) $y^2 + 16y + 64$
 e) $9x^2 + 42x + 49$
 h) $25x^2 + 110x + 121$

- c) $x^2 + 20x + 100$
 f) $36y^2 + 84y + 49$
 i) $64x^2 + 224x + 196$

B 139

- a) $x^2 - 6x + 9$
 d) $x^2 - 14x + 49$
 g) $16a^2 - 56a + 49$

- b) $y^2 - 8y + 16$
 e) $4x^2 - 12x + 9$
 h) $25x^2 - 90x + 81$

- c) $a^2 - 12a + 36$
 f) $16x^2 - 48x + 36$
 i) $36x^2 - 96x + 64$

B 140

- a) $x^2 - 16$
 d) $b^2 - 49$
 g) $16y^2 - 36b^2$

- b) $y^2 - 25$
 e) $4x^2 - 25$
 h) $16x^2 - 49y^2$

- c) $x^2 - 64$
 f) $9y^2 - 16$

B 141

- a) $29a^2 - 12a - 18$
 d) $6x^3 - 13x^2 - 11x - 20$
 f) $-44x^2 + 72x - 43$

- b) $-11x^2 - 4x - 50$
 e) $-12y^3 - 56y^2 - 60y + 11$

- c) $-8x^2 - 30x + 63$

B 142

$$a = 5, b = 9, c = 8, d = 7$$

B 143

$$a = 10, b = 3, c = 2, d = 5, e = 4$$

B 144

-

B 145

$$\begin{aligned} (x + y)(x + y) + (x - y)(x - y) &= \\ x^2 + xy + xy + y^2 + x^2 - xy - xy + y^2 &= \\ 2x^2 + 2xy + 2y^2 - 2xy &= \\ 2(x^2 + y^2) \end{aligned}$$

B 146

$$\frac{1}{\pi} \cdot A = \pi \cdot r^2 \cdot \frac{1}{\pi} \quad r^2 = \frac{A}{\pi} \Rightarrow r = \sqrt{\frac{A}{\pi}}$$

B 147

a) 144 b) - 297

B 148

a) $8\frac{4}{9}$ b) $73\frac{1}{3}$

B 149

a) - 7 b) - 22

B 150

a) Formel for arealet: $A = a^2 + 3ab$

Formel for omkretsen/omkrinsen: $O = 8a + 2b$

b) $A = 261,34 \text{ m}^2$ $O = 77,4 \text{ m}$

B 151

a) Formel for arealet. $A = 2ab + \frac{ab}{2}$ b) $12,5 \text{ cm}^2$

B 152

a) Tirsdag/Tysdag

b) De satte ikke garn den dagen./Dei sette ikkje garn den dagen.

c) 39 kg d) $14x + 25y$ e) 58 kr**B 153**

a) Arealet av figuren: $A = 2xy + y^2 + \frac{1}{4}\pi x^2$

Omkretsen/Omkrinsen av figuren: $O = 2x + 4y + \frac{1}{2}\pi \cdot x$

b) $A \approx 30,0 \text{ cm}^2$ $O \approx 21,3 \text{ cm}$

B 154

a) Arealet av figuren: $A = \frac{x^2(2 + \pi)}{4}$ b) $A \approx 25 \text{ cm}^2$

B 155

a) 81 kg b) $18x$ c) $60x + 21(x + 5)$ d) 65,00 kr

B 156

a) Arealet av figuren: $A = a^2 + \frac{\pi a^2}{4} = \frac{4a^2 + \pi a^2}{4} = \frac{a^2(4 + \pi)}{4}$

Omkretsen/Omkrinsen av figuren: $O = 2\pi \cdot a$

b) $A \approx 48,3 \text{ cm}^2$ $O \approx 32,7 \text{ cm}$

B 157

-

B 158

$A \approx 31 \text{ cm}^2$ $O = 27,5 \text{ cm}$

B 159

a) $\frac{2}{3b}$ b) $\frac{2}{5x}$ c) 9 d) $\frac{1}{4a}$ e) $\frac{1}{3xy}$ f) $\frac{c}{3a}$

g) $\frac{a}{3c}$ h) $\frac{5}{3xy}$

B 160

a) $\frac{7x-8}{19}$ b) $\frac{4a-13}{3a+b}$ c) 0 d) $\frac{5y}{x^2+y}$

B 161

a) $\frac{5}{6}$ b) $\frac{a+b}{ab}$ c) $\frac{17}{5x}$ d) $\frac{19}{10x}$ e) $\frac{5y+3x}{xy}$ f) $\frac{2y-3x}{3xy}$

B 162

a) $\frac{4x+3}{x}$ b) $\frac{9x-2}{x}$ c) 1 d) $\frac{11x+1}{3}$ e) $\frac{9x+7}{5}$ f) $\frac{x-7}{2}$

B 163

a) $\frac{3x}{x-1}$ b) $\frac{x+1}{x+5}$

B 164

a) $\frac{7x-3}{x+2}$ b) $\frac{x+3}{2}$

B 165

a) $\frac{1}{6}$ b) $\frac{1}{xy}$ c) $\frac{1}{3xy^2}$ d) $\frac{y^2}{x^4}$ e) $\frac{y}{x}$ f) $\frac{y}{2x}$

B 166

a) $\frac{3}{5}$ b) xy c) $\frac{xy}{2}$ d) $\frac{3}{2x}$

B 167

a) $\frac{8}{15}$ b) $\frac{5}{6}$ c) $\frac{10}{8} = 1\frac{1}{4}$ d) $\frac{289}{144} = 2\frac{1}{144}$ e) $\frac{4}{5}$
 f) $\frac{10}{3} = 3\frac{1}{3}$

B 168

a) $\frac{3}{5}$ b) $\frac{2x+3}{x+5}$ c) $\frac{1}{2}$ d) $\frac{1}{5}$ e) 3 f) $\frac{1}{5}$

B 169

a) 2 b) 5 c) 2 d) $\frac{x^2-4x+4}{2x-2}$

B 170

a) $\frac{9x-1}{2(x+3)}$ b) $\frac{7x-2}{3(x-2)}$ c) $\frac{2a^2+2b^2}{a^2-b^2}$ d) $\frac{5x^2+12}{6x^2-24}$

B 171

a) $\frac{4x+13}{6(x+2)}$ b) $\frac{16-x}{10(x+3)}$ c) $1\frac{1}{3}$ d) $\frac{5x-30}{36x-54}$
 e) $\frac{4x^3+12x^2+7x+39}{6x(2x-3)(2x+3)}$ f) $\frac{7a+21}{6a^2+18a}$

B 172

a) $\frac{9}{8a-12}$ b) $\frac{-2a^2+2a+4}{a(a+2)}$ c) $\frac{3}{5(x-1)}$ d) $\frac{16-x}{10(x+3)}$
 e) $\frac{5x-30}{36x-54}$ f) $\frac{a}{a+1}$ g) $\frac{9x-11}{12(2x+1)}$ h) $\frac{x+2}{6x-12}$

B 173

- a) Fortegnsfeil i 2. linje og 3. linje./Forteiknfeil i 2. linje og 3. linje.
 b) Fortegnsfeil i siste linje./Forteiknfeil i siste linje.
 c) Fortegnsfeil i siste linje./Forteiknfeil i siste linje.

B 174

- a) Martin må faktorisere før han forkortar./Martin må faktorisere før han forkortar.

B 175

a) $1\frac{1}{3}$ b) $\frac{x+3}{x+2}$ c) $\frac{a+3}{3a+5}$ d) 3 e) $\frac{a^2+2a+3}{3a^2-2}$
 f) $\frac{2(2x-3)}{3x+1}$ g) $\frac{x}{3}$ h) $\frac{7a^2}{2}$

B 176

Lene har rett.

B 177

a) $(2x+3)^2$ b) $(3x+5)^2$ c) $(7x+3)^2$
 d) $(9x+6)^2$ e) $(5a+3b)^2$ f) $(3xy+5z)^2$

B 178

a) $(2a-5y)^2$ b) $(4x-3y)^2$ c) $(11a-12b)^2$
 d) $(6x-4y)^2$

B 179

a) $(x+5)(x-5)$ b) $(x+4)(x-4)$ c) $(x+9)(x-9)$
 d) $(a+8)(a-8)$ e) $(2a+3b)(2a-3b)$ f) $(5a+7b)(5a-7b)$

PRØV DEG SELV

PB 1

a) $9x = 27$ b) $5x - 3y + 3z = 18$

PB 2

a) $8a + 3$ b) $-x - 2y$ c) $-7a - b$

PB 3

a) $12x + 20$ b) $10x^2 - 35x$

PB 4

a) $x^2 + 8x + 15$ b) $6x^2 - x - 15$ c) $4y^2 - 39y + 27$

PB 5

a) $16x^2 - 56x + 49$

PB 6

a) $2x^2 + 29x + 17$ b) $-10x^2 + 37x - 32$
 c) $-6x^3 + 30x^2 - 36x + 14y^2 - 17y + 21$
 d) $20x^2 - 20x + 25$ e) $21y^2 - 16y + 50$

PB 7

a) $\frac{2}{5}$ b) $\frac{3}{5}$

PB 8

a) $\frac{3}{4}$ b) $\frac{5}{18}$

PB 9

a) $\frac{7}{12}$ b) 1 c) $\frac{11}{12}$ d) $\frac{8}{15}$ e) $\frac{16}{27}$ f) $\frac{22}{7} = 3\frac{1}{7}$
 g) 2 h) $\frac{2}{3}$ i) $\frac{5}{3} = 1\frac{2}{3}$

PB 10 $\frac{5}{6}$ er størst**PB 11** $\frac{2}{5}$ **PB 12**

15 timer

PB 13

80 g makaroni
 4 dl melk/mjølke
 $\frac{1}{3}$ revet muskatnøtt/riven muskatnøtt
 $\frac{1}{6}$ hvit pepper/kvit pepar
 2 egg
 100 g kokt skinke

PB 14

8 flasker

PB 15 $\frac{1}{5}$ **PB 16** $\frac{3a}{5}$ **PB 17**a) $\frac{3}{4}$ b) $\frac{9}{80}$ c) $\frac{7}{2x}$ d) $\frac{5}{3a}$ e) $\frac{2x+5}{2}$ f) $3\frac{5}{6}$ g) $2\frac{5}{8}$ h) $4\frac{1}{30}$ **PB 18**a) $42a + 22b + 50c + 2d$

b) 485 kr

TEMAOPPGAVE: GLIMT FRA MATEMATIKKENS HISTORIE

TB 1a) b) c) d) **TB 2**a) b) c) d) **TB 3**

400 000 okser/oksar, 1 421 000 geiter, 120 000 fanger/fangar

TB 4a) 14 $(x + \frac{x}{7} = 16)$ **TB 5**

-

TB 6

-

TB 7

84 år

TB 8**TB 9**144 hunnkaniner
(1, 1, 3, 5, 8, 13, 21, 34, 55, 89, 144, ...)**TB 10**

15

TB 11

-

TB 12

-

FASIT TIL KAPITTEL C

ANVENDT MATTEMATIKK

C 1 a) 300 km b) 600 km c) 4000 km d) 10 500 km e) 30 km

C 2 a) ≈ 67 km/t b) 67 km/t c) 87,5 km/t d) 60 km/t

C 3 1100 km/t

C 4 a) 2 t b) 2 t c) 3 t d) 2 t

C 5 a) 4 t b) 2 t 30 min c) 2 t

C 6 a) 2 t 30 min b) 3 t 12 min c) 4 t 27 min d) 3 t 15 min e) 4 t 6 min
f) 21 min g) 40 min 48 s h) 8 t 42 min

C 7 a) 4 min 36 s b) 3 min 48 s c) 1 min 30 s d) 6 min 54 s e) 8 min 18 s
f) 16 min 24 s g) 6 min 3 s h) 5 min 6 s

C 8 a) $\approx 1,67$ t b) 3,8 t c) 6,9 t d) $\approx 4,42$ t e) $\approx 2,12$ t
f) $\approx 9,83$ t

C 9 a) $\approx 4,47$ min b) 3,7 min c) 7,2 min d) $\approx 12,23$ min
e) $\approx 8,87$ min f) 18,8 min

C 10 a) $\approx 1,4$ m/s b) $\approx 5,6$ m/s c) $\approx 16,7$ m/s d) 250 m/s e) ≈ 583 m/s

C 11 a) 43,2 km/t b) 36 km/t c) 28,8 km/t d) 432 km/t

C 12 a) 6 m/s b) 21,6 km/t c) 1 min 23 s

C 13

- a) USA, Storbritannia og land som bruker euro
 b) 1 dansk krone \approx 1,04 norsk krone
 1 svensk krone \approx 0,84 norsk krone
 1 islandsk krone \approx 0,09 norsk krone
 1 sveitsisk franc \approx 4,66 norsk krone
 1 pund sterling \approx 11,12 norsk krone
 c) 100 danske kroner er 103,84 norske kroner. Vi finner da prisen på 1 dansk krone ved å dele på 100./100 danske kroner er 103,84 norske kroner, Vi finn da prisen på 1 dansk krone ved å dele på 100.

C 14

63,50 NOK

C 15

259 NOK

C 16

31,34 NOK

C 17

3530,56 NOK

C 18

72,35 EUR

C 19

134,89 GBP

C 20

238,20 NOK

C 21

9,48 USD

C 22

234,55 USD

C 23

a) 46 % jenter 54 % gutter b) 37,5 % jenter 62,5 % gutter

C 24

50 %

C 25

20 %

C 26

20 %

C 27

40 %

C 28

20 %

C 29

15 %

C 30

20 %

C 31

a) 10 % b) 5,72 kr c) 75,4 %

C 32

30 spillere

C 33

500 kr

C 34

50 liter

C 35

120 m

C 36

11 429 kr

C 37

62,9 g

C 38

597,6 g

C 39

20,5 g

C 40

kl. 21.10

C 41

a) 12.35 b) 13.20 c) 15.30

C 42

6 t og 35 min

C 43

a) 19.10 b) 18.40

C 44

18.05

C 45

a) Strekning b) Fart c) Tid d) –

C 46

a) 54 km b) 2080 km c) 40 km d) 1 km

C 47	a) 160 km	b) 480 km	c) 40 km
C 48	a) 200 km	b) 320 km	c) 50 km
C 49	780 km	C 50	912 000 km
C 51	a) 20 km/t	b) 15 km/t	c) 40 km/t
C 52	a) 50 km/t	b) 30 km/t	c) 75 km/t
C 53	60 km/t	C 54	75 km/t
		C 55	31 km/t
C 56	a) 3 t	b) 2 t	c) 1 1/2 t
C 57	a) 3 t	b) 1 t	c) 1/2 t
		C 58	5 t
C 59	a) = k) = f) b) = r) = d)	e) = i) = m) c) = n) = j)	g) = q) = l) p) = o)
C 60	a) 3 t 30 min	b) 8 t 48 min	c) 4 t 18 min d) 1 t 45 min
C 61	a) 1 t 24 min	b) Ole	
C 62	a) 2,25 t	b) 2,6 t	c) 2,75 t d) 2,9 t
C 63	a) 3,8 t	b) 38 km	C 64
			40 km/t
C 65	a) 60 km	b) 7,5 km/t	C 66
			3 t 30 min
		C 67	892 km/t
C 68	a) 88,96 NOK 63,36 NOK	b) 44,48 NOK 42,24 NOK	c) 68,64 NOK 88,96 NOK
			d) 116,10 NOK 132,00 NOK
C 69	a) 39 EUR	b) 400 NOK	c) 230 NOK
C 70	310 NOK	C 71	526 NOK
		C 72	1335 NOK
C 73	41,79 NOK	C 74	a) 223,82 NOK 300,24 NOK b) 74,42 kr

C 75	a) England	b) Pund sterling	c) 316,55 GBP
C 76	a) Euro	b) 239 SEK	c) 261,62 EUR
C 77	a) 0,18	b) 0,37	c) 0,06
C 78	a) 16/100	b) 58/100	c) 95/100
C 79	a) 35 % e) 125 %	b) 69 % f) 87 %	c) 8 % g) 260 % d) 7 % h) 17,5 %
C 80	Prosent 10 % 58 % 60 % 75 % 40 % 1 %	Brøk 10/100 58/100 6/10 75/100 40/100 1/100	Desimal 0,10 0,58 0,6 0,75 0,4 0,01
C 81	a) 42 kr d) 22,50 kr	b) 24 liter e) 2960 kr	c) 780 kg f) 5,95 gram
C 82	a) 32 tonn	b) 3,6 kg	c) 840 kr d) 66,4 gram
C 83	6 elever	C 84	3,5 kg
C 85	a) 1760 kr	b) 23 760 kr	
C 86	a) 120 kr	b) 245 kr	
C 87	a) 27 %	b) Kino 120 kr Klær 300 kr Smågodt 288 kr Brus 168 kr Diverse 324 kr	
C 88	a) 168 elever	b) 72 elever	
C 89	a) 300 kr	b) 2300 kr	C 90 90 gram sølv

C 91	a) 280 kr	b) 160 kr	c) 292,50 kr	d) 180 kr
C 92	a) 12 640 kr	b) 145 360 kr		
C 93	a) 300 kr	b) 140 kr	c) 6960 kr	
C 94	a) 4,8 kg	b) 84,8 kg		
C 95	a) 294 kr	b) 73,50 kr		
C 96	a) 22	b) 27,2 %	c) 72,8 %	d) 100 %
C 97	a) 4	b) 25 %	c) 75 %	
C 98	a) 148 bilførere	b) 7,5 %	c) 92,5 %	
C 99	a) 420 kr f) 370 kr	b) 170 kr g) 1) 15 uker 2) 11 uker 3) 10 uker	c) 160 kr	d) 280 kr e) 1120 kr
C 100	a) 1990 km (én vei) e) 12,84 NOK	b) 69 km/t f) 2080 NOK	c) 186 liter g) 2000 Dkk og 359 euro	d) 11,67 Dkk
C 101	a) 8 t 46 min c) 6 timer	b) Årets korteste dag fra soloppgang til solnedgang		
C 102	a) 9 t 53 min	b) Opp når månebuen (sigden) peker mot høyre.		
C 103	a) $s = \text{strekning}, v = \text{fart}, t = \text{tid}$	b) –		
C 104	a) 128 km d) 135 m	b) 2490 km e) 18 000 000 km	c) 0,96 km	
C 105	5625 km	C 106	455 km	
C 107	a) 1700 m	b) $9,46 \cdot 10^{12}$ km	c) 10 km	
C 108	a) 1 t 48 min d) 0 t 30 min	b) 2 t 42 min e) 0 t 45 min	c) 5 t 18 min f) 0 t 6 min	

C 109	a) 2 min 24 s d) 0 min 15 s	b) 1 min 30 s e) 0 min 30 s	c) 0 min 42 s f) 1 min 12 s		
C 110	a) 0,75 t d) 3,13 t	b) 0,50 t e) 7,83 t	c) 0,167 t f) 3,4 t		
C 111	338 km	C 112	13,3 km	C 113	58,3 km
C 114	8 km/t	C 115	a) 50 km/t	b) 75 km/t	c) 81,8 km/t
C 116	65,9 km/t	C 117	37,3 km/t	C 118	140 km
C 119	a) 100 km	b) 65,6 km/t	c) 2 t 40 min		
C 120	10 min	C 121	a) 36 km/t	b) 144 km/t	c) 21,6 km/t
C 122	a) 6,9 m/s	b) 22,2 m/s	c) 41,7 m/s		
C 123	a) 0,5 km/min	b) 1,5 km/min	c) 1,2 km/s		
C 124	a) 833 m/s	b) 50 km/min	c) 0,83 km/s		
C 125	1,96 s	C 126	SR-71 2,8 mach Visper 2,1 mach Bong 747 0,8 mach		
C 127	83,3 km/t	C 128	55,6 km/t		
C 129	a) 70 km/t f) 28 km	b) 40 min pause g) 60 km/t	c) 51,4 km/t h) Mer bratt kurve, større fart	d) 2 t 45 min	e) 64 km/t i) Lik fart
C 130	a) Storbritannia, Sverige, Danmark, Tyskland og Sveits b) 77,84 NOK, 484,76 NOK, 145,38 NOK, 150,93 NOK, 55,96 NOK				
C 131	a) 333,60 NOK b) 7 753 420 NOK				
C 132	1926 DKK, 387,60 EUR				

C 133	a) CHF d) 600 franc	b) Sveitserfranc e) 2847,80 NOK	c) 466,30
C 134	10,83 NOK	C 135	7,50
C 136	454,167		
C 137	I banken	–	C 138
C 139	a) 1920 kr	b) 405 kr	c) 3450 kr
		d) 264,60 kr	
C 140	c) 75 %	C 141	b) 6 %
		C 142	c) 16 2/3 %
C 143	a) 8 kr	b) 12,16 liter	c) 1150 kr
		d) 65,7 gram	
C 144	15,21 gram	C 145	7 gram
		C 146	30 %
C 147	a) 3957 kr	b) 3746,25 kr	c) 840 kr
C 148	32 %	C 149	12,5 %
		C 150	7,5 %
C 151	1550 passasjerer	C 152	450 juletrær
		C 153	44 %
C 154	17,9 %	C 155	1207 kr
C 156	a) 10 000 kr	b) 10 500 kr	
C 157	a) 130 000 kg	b) 8,5 kg	C 158
			140 kg
C 159	a) 4600 kr	b) L: 1840 kr E: 1150 kr	
C 160	a) Lysgård: 75 kr Flaskerud: 60 kr c) 768 km f) L: 1164 kr F: 1296 kr	d) 576 kr g) –	b) 13 uker 9 uker e) 11 kr
C 161	3750 kr		

C 162

- a) 300 km b) 3 t 30 min c) 50 km/t d) 1170 NOK, han tjente 270 kr
 e) 228 km f) 1023 km g) 17 t h) 60 km/t

C 163

- a) 4 t 31 min 5 t 54 min 0 t 0 min b) 38 min
 c) 30 min

C 164

- a) 4,3 km b) 585 km

C 165

- a) $1,326\ 325 \cdot 10^6$ km b) 10 833 m/s
 c) 10,8 km/s d) 648 km/min

C 166

1,2 km

C 167

52,5 km/t

C 168

120,4 km/t

C 169

- a) 103,7 km/t b) 116,7 km/t c) 28,8 m/s og 32,4 m/s

C 170

- a) 112,6 km/t b) 95,5 km/t c) 80,5 km/t

C 171 $\approx 23,2$ km/t**C 172** $\approx 17,9$ km/t**C 173**

- a) 33 t 29 min b) $\approx 173,4$ km/t

C 174

- a) 3 døgn 10 t 52 min

C 175 $4\ 132\ 596$ km/døgn = 172 191,5 km/t**C 176**

-

C 177

- a) - b) - d) ca. 56 min e) 20 km fra Smijordet

- c) Vi har brukt gjennomsnittsfarten til mopedene. De klarer ikke å kjøre jevnt på den hele veien.

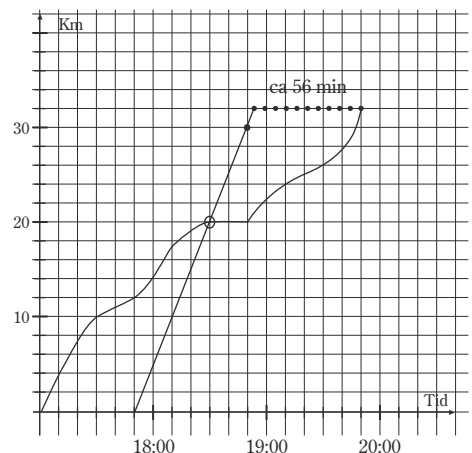

C 178	a) 7 t (Helst litt fart!) d) ca. 65 km	b) Maks 77,78 km	c) 37,5 km
C 179	Tørr a) 93,3 m b) 41,7 m c) 18,3 m	Is a) 342 m b) 139 m c) 53,3 m	
C 180	210 km	C 181	a) 61,54 km/t b) Nei, avstanden forkortes bort i beregningene. Forsøk med en variabel avstand.
C 182	3,0 km	C 183	1562,10 NOK
C 184	a) 292,50 DKK b) 303,73 NOK c) 288,47 NOK		
C 185	a) Belgia b) 2137,80 NOK	C 186	3685,80 NOK
C 187	Kurs 7,40		
C 188	a) – b) ca. 840 NOK c) ca. 54 CHF		
C 189	a) 110 e) 46,20 NOK	b) 120	c) – d) A: 64 euro B: 70 euro
C 190	a) 18 % b) 0,7 % c) 20 % d) 16,67 % e) 30 %		
C 191	b) 42 %		
C 192	a) 77	b) Drama: 20,7 % Fransk: 18,2 % Ballspill: 23,4 % Skoleavis: 10,3 % Elektronikk: 19,5 % Porselensm.: 7,8 %	
C 193	56 %	C 194	11,7 %
C 195	a) 160 b) Røde: 80 Gule: 40 Blå: 16		

C 196	8. klasse: 31,0 % 9. klasse: 33,3 % 10.klasse: 35,7 %
C 197	1 476 500 stemte C 198 4,8 %
C 199	a) 7,93 m b) 48,7 % lengre
C 200	a) 4 230 769 kr b) 4 780 769 kr
C 201	Til Sverige: 63,7 % Til Finland: 28,6 % Til Russland: 7,7 %
C 202	a) Ja: 46,5 % Nei: 53,5 % b) 2 646 036 stemmeberettigede c) Nei: 87,2 % Ja: 12,8 %
C 203	1 g C 204 a) 3600 kr b) 20 %
C 205	a) ca. 81 NOK b) \approx 49 %
C 206	a) 20 % mindre b) 25 % mer
C 207	a) 6 kg b) 75 kg
C 208	1 200 000 kr C 209 1,7 ‰ C 210 300 kr
C 211	122,5 g salter C 212 a) 0,1 % b) 10 % c) 11,1 %

PRØV DEG SELV

PC 1	a) 240 km b) 30 km c) \approx 136 km
PC 2	a) 7 km/t b) 9,33 km/t c) 7,78 km/t
PC 3	2 t 28 min PC 4 a) 2541 kr b) 771,4 km/t c) 0,63 mach

PC 5

- a) Tur med jevn fart. Pause etter en time b) 36 min pauser
c) 14 km/t d) 3 timer e) 18,6 km/t f) 13,3 km/t

PC 6

924 NOK

PC 7

- a) 5 % b) 42 % c) 20 % d) 75 %

PC 8

- a) 50 kr b) 15 gram c) 1040 kr

PC 9

1470 kr

PC 10

34,5 % menn

PC 11

300 kr

PC 12

500 kr

FASIT TIL FYLKESOPPGAVE AKERSHUS

FC 1

- a) 11 kommuner b) A & B $\frac{2}{22} = \frac{1}{11}$
Follo $\frac{9}{22}$
Romerike $\frac{11}{22} = \frac{1}{2}$ c) A & B $\approx 4 \%$
Follo $\approx 20 \%$
Romerike $\approx 76 \%$
- d) A & B 160 585 e) 45 %

FC 2

a)

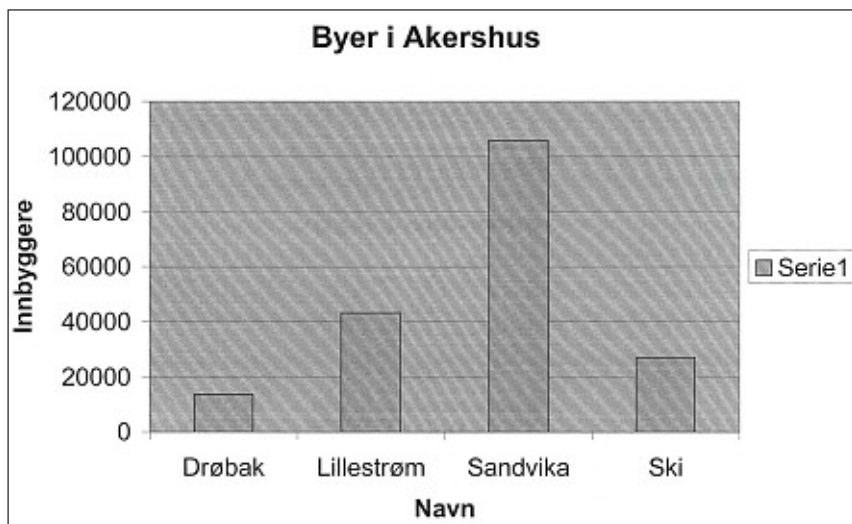

- b) 22,8 %

FC 3

- a) 0-0 1-0 0-1 1-1 2-1 1-2 2-2 2-0 0-2
 b) 0-0 1-1 2-2 3-3 4-4 $n-n$
 1 4 9 16 25 $(n + 1)^2$

FC 4

- a) 3400 plasser b) 6000 plasser c) 75,5 %

FC 5

- a) 1 676 167

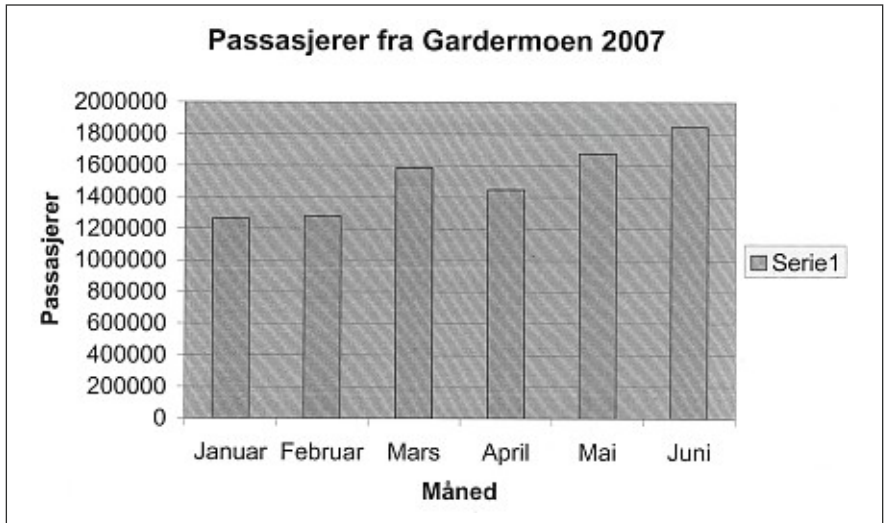

- c) Utland 53,3 % d) 1 591 801 e) -
 Innland 46,7 %

FC 6

- a) 6,55 km b) Runway (Rullebane)

FC 7

- a) - b) $1,4 \cdot 10^5 \text{ m}^2$

FC 8

- a) - b) 1853 c) 0,63 m d) $\approx 3,4 \text{ km}$
 e) 850 500 tonn f) ca. 800 m g) ca. 1 s h) 23 %
 i) 1 : 16 000